

CASA Draft AC139-10 Vertical Flight Facilities (2025)



Guidelines for vertical flight aircraft facilities at aerodromes designed for aeroplanes

File ref: D24/289111

June 2025



Acknowledgement of Country

The Civil Aviation Safety Authority (CASA) respectfully acknowledges the Traditional Custodians of the lands on which our offices are located and their continuing connection to land, water and community, and pays respect to Elders past, present and emerging.

Artwork: James Baban.

Advisory circulars are intended to provide advice and guidance to illustrate a means, but not necessarily the only means, of complying with the Regulations, or to explain certain regulatory requirements by providing informative, interpretative and explanatory material.

Advisory circulars should always be read in conjunction with the relevant regulations.

Audience

This advisory circular (AC) applies to:

- aerodrome operators
- persons involved in the design, construction, and operation of airports, heliports, and vertiports.
- proponents of airports, heliports, and vertiports
- helicopter and VTOL capable aircraft (VCA) owners/operators
- planning authorities
- the Civil Aviation Safety Authority (CASA).

Purpose

The purpose of this AC is to provide guidance to aerodrome and aircraft operators in the planning, design, and operation of both helicopter and vertical take-off and landing (VTOL) capable aircraft (VCA) facilities on an aerodrome that may have only been designed for fixed wing aeroplanes.

The information in this AC is intended to focus on aviation safety matters; however, other forms of safety may be mitigated.

It is not intended to limit aircraft operations.

Note: This AC should be read in conjunction with the Part 139 Manual of Standards (MOS) and AC's 139.R-01 Guidelines for heliports - design and operation and 139.V -01 - Guidance for vertiport design. These documents provide supporting and/or detailed information for various sections throughout the AC.

For further information

For further information or to provide feedback on this AC, visit CASA's contact us page.

Unless specified otherwise, all subregulations, regulations, Divisions, Subparts and Parts referenced in this AC are references to the Civil Aviation Safety Regulations 1998 (CASR).

Status

This version of the AC is approved by the National Manager, Flight Standards Branch.

Table 1: Status

Version	Date Details	
v1.0	June 2025	Draft issue for regulatory consultation.

Guidelines for vertical flight aircraft facilities at aerodromes designed for aeroplanes

Contents

1 Reference material	6
1.1 Acronyms	6
1.2 Definitions	7
1.3 References	11
2 Introduction	13

2.1	Background	13
2.2	Defining the operations	14
2.3	Arrival and departure procedures	20
3	Physical characteristics of aerodrome vertical flight facilities	23
3.1	General	23
3.2	Physical facilities	24
3.3	Final approach and take-off area	24
3.4	Nominating a runway or taxiway as a FATO	25
3.5	Aiming point or TLOF	28
3.6	Nominating taxi-routes and transit routes	29
3.7	Aprons for vertical flight aircraft	35
4	Obstacle limitation surfaces	43
4.1	Aeronautical assessments	43
4.2	OLS general specifications	43
5	Visual aids	46
5.1	General	46
5.2	Options for marking the FATO	46
5.3	Touch down positioning marking and circle	50
5.4	Marking the taxiways and taxi-routes	51
5.5	Marking stands and aprons	52
5.6	Vertical flight visual aids - Lighting	54
6	Published information	58
6.1	Vertical flight aircraft facility data	58

1 Reference material

.1 Acronyms

The acronyms and abbreviations used in this AC are listed in the table below.

Table 2: Acronyms

Acronym	Description
AAM	advance air mobility
AC	advisory circular
AIP	aeronautical information publication
ATC	air traffic control
ATSB	Australian Transport Safety Bureau
CASA	Civil Aviation Safety Authority

CASR	Civil Aviation Safety Regulations 1998
DPZ	downwash and outwash protection zone
DW/oW	downwash and outwash
ERSA	en-route supplement (Australia)
FATO	final approach and take-off area
FATO/SA	final approach and take-of area/safety area
ICAO	International Civil Aviation Organization
LDAH/LDAV	landing distance available (helicopter/VCA)
MOS	Manual of Standards
MTOW	maximum take-off weight
NAA	national aviation authorities (FAA, EASA, UK CAA etc)
OEM	original equipment manufacturer
OLS	obstacle limitation surface
PinS	point-in-space (instrument flight procedure)
RTODAH/RTODAV	rejected take-off distance available (helicopter/VCA)
SA	safety area
SARPS	standards and recommended practices
TDPC	touchdown/positioning circle
TDPM	touchdown/positioning marking
TLOF	touchdown and lift-off area

Guidelines for vertical flight aircraft facilities at aerodromes designed for aeroplanes

Acronym	Description
TODAH/TODAV	take-off distance available (helicopter/VCA)
VCA	VTOL capable aircraft
VTOL	vertical take-off and landing
VTSS	take-off safety speed

1.2 Definitions

Terms that have specific meaning within this AC are defined in the table below. Where definitions from the civil aviation legislation have been reproduced for ease of reference, these are identified by 'grey shading'. Should there be a discrepancy between a definition given in this AC and the civil

aviation legislation, the definition in the legislation prevails.

Table 3: Definitions

Term	Definition
aerodrome	From the Civil Aviation Act 1988:
	An area on land or water (including any buildings, installations, and equipment), the use of which as an aerodrome is authorised under the regulations, being such an area intended to be used either wholly or in part for the arrival, departure, and movement of aircraft.
D	For rotorcraft, the maximum dimension of the rotorcraft.
	Typically, it is the largest overall dimension of the helicopter when rotor(s) are turning measured from the most forward position of the main rotor tip path plane to the most rearward position of the tail rotor tip path plane or helicopter structure.
	For VTOL-capable aircraft, means the diameter of the smallest circle enclosing the aircraft projected on a horizontal plane, while the aircraft is in the take-off or landing configuration, with lift/thrust units turning, if applicable.
	Note: If the aircraft changes dimensions during taxiing or parking (e.g. folding wings), a corresponding $D_{taxiing}$ or $D_{parking}$ should also be provided.
design D	The D of the design vertical flight aircraft.
D-value	A limiting dimension, in terms of "D", for a vertical flight facility, or for a defined area within.
declared distances -	For example: The D-value for a size of FATO is $1.5 \times$ Design D of the largest aircraft. Take-off distance available (helicopter or VCA):
heliports	<ul style="list-style-type: none"> • Take-off distance available (TODAH or TODAV) means the length of the FATO plus the length of helicopter clearway (if provided) declared available and suitable for helicopters to complete the take-off.
	Where a clearway is provided then the TODAH/TODAV will be the FATO
	length, plus the length of the clearway, plus the safety/protection area that is
	located between the two.
Rejected take-off distance available:	

Term	Definition
	Rejected take-off distance available (RTODAH or RTODAV) will be length of the FATO declared available and suitable for helicopters operated in performance class 1 to complete a rejected take-off.
	Landing distance available: Landing distance available (LDAH): length of the FATO plus any additional area declared available and suitable for helicopters to complete the landing manoeuvre from a defined height.
downwash protection zone	The downwash protection zone is designed to protect the general public, other aircraft and those working in the immediate vicinity of an operating helicopter or VCA from the hazards of downwash and outwash.
dynamic load-bearing surface	A surface capable of supporting all types of loads generated by a vertical flight aircraft in motion.
elongated	When used with TLOF or FATO, elongated means an area which has a length more than twice its width.
final approach and take-off area (FATO)	For the operation of a rotorcraft at an aerodrome, means the area of the aerodrome: a. from which a take-off is commenced; or b. over which the final phase of approach to hover is completed.
	For the operation of a VTOL-capable aircraft, is defined as a solid area: a. from which a take-off is commenced; or b. over which the final phase of approach to hover is completed.
flight manual clearway	for an aircraft: see clause 37 of Part 2 of the CASR Dictionary. A defined area on the ground or water, selected and/or prepared as a suitable area over which a vertical flight aircraft operating in performance class 1, or a
	vertical flight aircraft, capable of continued safe flight after a critical failure, may accelerate and climb to a specific height. An aerodrome, including a heliport, intended for use wholly or partly for the
	arrival, departure, or movement of helicopters and, when designed to and capable of accommodating, other rotorcraft or VTOL capable aircraft. A defined area intended to accommodate vertical flight aircraft for purposes of
stand	loading or unloading passengers, mail or cargo; fuelling, parking or maintenance; and, where air taxiing operations are contemplated, the TLOF. A defined path on a heliport intended for the ground movement of vertical flight
taxiway	aircraft and that may be co-located with an air taxi-route to permit both ground and air taxiing. A defined path established for the movement of vertical flight aircraft from one

taxi-route	part of a heliport to another. a. Air taxi-route. A marked taxi-route intended for air taxing. b. Ground taxi-route. A taxi-route centred on a taxiway.
lighting segment	Lighting segments are low profil lighting fixtures that consists of a line of lighting elements within unit or frame.
obstacle	A fixed (whether temporarily or permanently) or mobile object, structure, or part of such objects and structures, that:

DRAFT

Guidelines for vertical flight aircraft facilities at aerodromes designed for aeroplanes

Term	Definition	
	a. b.	is located on an area provided for the surface movement of aircraft; or extends above a defined surface designated to protect aircraft in flight;
	C.	or stands outside the defined surfaces mentioned in paragraphs (a) and (b)
obstacle limitation	a.	and that have been assessed as being a hazard to air navigation. of an aerodrome, means a surface associated with the aerodrome that
surfaces	b.	is ascertained in accordance with the requirements prescribed by the Part 139 Manual of Standards for the purposes of this definition, or for a vertical flight facility, means surfaces extending outwards and upwards from the FATO safety area (protection area) at angles
		compatible with the flight characteristics of the intended vertical flight aircraft, used to evaluate approach and take-off climb surfaces for clearance of obstacles.
performance class	Manual of Standards.	For a stage of flight of a rotorcraft, has the meaning given by the Part 133
rejected take-off area	class 1 to complete a rejected take-off.	A defined area on a heliport suitable for helicopters operating in performance
runway-type FATO		A FATO having characteristics similar in shape to a runway A runway type FATO wil most likely be associated with helicopter operating

	Note:	PC1 where the AFM (or the AOCs procedures) requires a rolling take-off with/or an aircrafts published rejected take-off distance that cannot be accommodated by a traditional FATO.
FATO protection area (or safety area)		A defined area surrounding the FATO which is free of obstacles, other than those required for air navigation purposes, and intended to reduce the risk of damage to helicopters accidentally diverging from the FATO.
static load bearing surface		A surface capable of supporting the mass of an aircraft situated on it.
strategically important		Means an HLS declared by a state or territory to be of critical need to the
helicopter landing site	a.	provision of identified services, including: an HLS associated with a hospital; or
	b.	an HLS provided with point-in-space (PinS) approach instrument flight
	procedures; or C.	any other facility identified as strategic by State/Territory or Commonwealth government/authorities.
touchdown and lift-off		The surface over which the touchdown and liftoff is conducted.
area (TLOF)		Note: A TLOF may be collocated with a FATO, or a stand.
touchdown positioning circle (TDPC)	positioning in a TLOF.	A touchdown positioning marking in the form of a circle use for omnidirectional
touchdown/positioning		A marking or set of markings providing visual cues for the positioning of vertical
marking (TDPM) touchdown/positioning (marking) shoulder line	flight aircraft.	A marking or set of markings providing visual cues for the positioning of vertical

DRAFT

Guidelines for vertical flight aircraft facilities at aerodromes designed for aeroplanes

Term	Definition
vertical flight aircraft	collectively used to describe helicopters, VTOL capable aircraft and other aircraft capable of performing vertical procedures

vertical procedures	take-of and landing procedures that include an initial and/or final vertical profile. The profile may or may not include a horizontal component.
VCA (VTOL capable aircraft)	a heavier-than-air aircraft, other than aeroplane or helicopter, capable of performing vertical procedures by means of more than two lift/thrust units.

Table 4: Manoeuvring of helicopters and VTOL capable aircraft in relation to a vertical flight facility

Note: For this AC , the following terms have specific meaning for describing the manoeuvring of helicopters and VTOL capable aircraft in relation to a vertical flight facility.

Term	Definition
touchdown	A manoeuvre whereby the aircraft's vertical momentum is arrested to a point where safe contact with the ground is made. In a purely vertical procedure, horizontal momentum will also be or has already been decreased to zero.
lift-off	A manoeuvre whereby the aircraft's vertical velocity becomes positive, and the aircraft safely leaves the ground. In a purely vertical procedure, horizontal momentum will remain at zero.
landing	A manoeuvre or manoeuvres that safely bring the aircraft from the landing decision point either to touchdown, where a TLOF is collocated with a FATO, or to a low hover, less than 10 feet, where a TLOF is not collocated with a FATO. The landing decision point is the last position from which a balked landing may be executed and beyond which the aircraft is committed to landing.
take-off	A manoeuvre or manoeuvres that safely bring the aircraft from either lift-off, where a TLOF is collocated with a FATO, or from a low hover, less than 10 feet, where a TLOF is not collocated with a FATO, to a height of 35 feet above the FATO, VPS and/or clearway and with a sufficient speed (VTOSS) to continue safe flight with a 35-foot clearance above any objects in the OLS ' area.

1.3 References

Legislation

Legislation is available on the Federal Register of Legislation website
<https://www.legislation.gov.au/>

Table 5: Legislation references

Document	Title
CASR	Civil Aviation Safety Amendment (Part 91, 133, 139, 175) Regulations 1998
Part 139 MOS	Part 139 (Aerodromes) Manual of Standards 2019
Part 133 MOS	Part 133 (Australian Air Transport Operations—Rotorcraft) Manual of Standards 2020
Part 91 MOS	Part 91 (General Operating and Flight Rules) Manual of Standards 2020

International Civil Aviation Organization documents

International Civil Aviation Organization (ICAO) documents are available for purchase from <http://store1.icao.int/> Many ICAO documents are also available for reading, but not purchase or downloading, from the ICAO eLibrary (<https://elibrary.icao.int/home>).

Table 6: ICAO references

Document	Title
ICAO SARPs	Annex 14 to the Convention on International Civil Aviation - Aerodromes - Volume II Heliports
ICAO Doc 9157	Aerodrome Design Manual
ICAO Doc 9261	Heliport Manual
ICAO Doc 10066	Aeronautical Information Management

Advisory material

CASA's advisory materials are available at <https://www.casa.gov.au/publications-and-resources/guidance-materials>

Table 7: Advisory material references

Document	Title
AC 1-01	Understanding the legislative framework
AC 19-16	Wake turbulence

AC 91-29	Guidelines for helicopters - suitable places to take-of and land
AC 133-01	Performance class operations
AC 139.R-01	Guidelines for heliports - Design and operation
AC 139.V-01	Guidelines for vertiport design

Guidelines for vertical flight aircraft facilities at aerodromes designed for aeroplanes

Table 8: International advisory material

Document	Title
Helicopter Rotor Downwash Safety	Preventing the Adverse Effects of Rotor Downwash.
Guidebook	Director Générale de l'Aviation Civile (DGAC) France and French Aviation Safety Network.
	Hyperlink: https://www.ecologie.gouv.fr/sites/default/files/quidance_material_helicopter_dow
NFPA 418	nwash.pdf National Fire Protection Association - Standards for Heliports and Vertiports
UK CAP 437	Standards for offshore helicopter landing areas.
	United Kingdom Civil Aviation Authority.
UK CAP 1246	Hyperlink: www.caa.co.uk/CAP437 Standards for helicopter landing areas at hospitals.
	United Kingdom Civil Aviation Authority.
UK CAP 2576	Hyperlink: www.caa.co.uk/CAP1246
	Understanding the downwash/outwash characteristics of eVTOL aircraft.
	United Kingdom Civil Aviation Authority.
	Hyperlink: www.caa.co.uk/CAP2576
UK CAP 3075	Protecting the Future: Trials and Simulation of Downwash and Outwash for Helicopters and Powered
	Lift Aircraft
	Hyperlink: www.caa.co.uk/CAP3075
FAA AC 150/5390-2D	Heliport Design
	Hyperlink:
	https://www.faa.gov/airports/resources/advisory_circulars/index.cfm/go/document

National Airports Safeguarding Framework principles and guidelines

National Airports Safeguarding Framework principles and guidelines are available at <https://www.infrastructure.gov.au/infrastructuretransport-vehicles/aviation/aviation-safety/aviation-environmental-issues/national-airports-safeguarding-framework/national-airportssafeguarding-framework-principles-and-guidelines>

Table 9: National Airports Safeguarding Framework principles and guidelines

Form number	Title
Guideline B	Managing the risk of building generated windshear and turbulence at airports
Guideline H	Protecting Strategically Important Helicopter Landing Sites

2 Introduction

2.1 Background

2.1.1 With the emergence of advance air mobility (AAM) the aerodrome industry may soon start to see new vertical flight capable aircraft operating at their facilities. When considering the introduction of new AAM aircraft at aerodromes designed to be used by aeroplanes, it became apparent to the future aerodromes team that hazards and risks involving AAM aircraft are similarly applicable to helicopter operations.

2.1.2 This AC provides guidance on the specifications that aerodrome operators may need to consider regarding the addition of vertical flight aircraft facilities at an existing aerodrome that had previously only been designed for fixed wing aeroplanes.

2.1.3 It provides operators of aerodromes designed for aeroplanes, guidance for designing facilities for these emerging aircraft types while also providing an explanation of the helicopter markings guidance in the Part 139 MOS.

Refer to AC 139.R-01 and AC 139.V-01 for additional information on helicopter markings.

2.1.4 The use of aerodromes designed for aeroplanes by vertical flight aircraft may include:

- a. common use of aerodrome facilities designed specifically using aerodrome reference code criteria
- b. stand-alone vertical flight aircraft facilities on an aerodrome specifically designed by using vertical flight aircraft design criteria
- c. shared use of runway to shared facilities or purpose-built facilities
- d. dependent or independent use of runway and vertical flight aircraft only final approach and take-off facilities (FATO)
- e. any combination of the above.

Note: It is not intended that aerodrome operators amend or upgrade aerodrome facilities to facilitate vertical flight aircraft, unless otherwise determined necessary through a hazard analysis or a risk assessment of existing or proposed vertical flight aircraft operations.

2.1.5 Vertical flight aircraft terminology

2.1.5.1 Due to the emerging nature of the AAM industry, internationally recognised terminology for AAM aircraft with VTOL capabilities has not been agreed upon. In AC 139.V-01, VTOL capable AAM aircraft are referred to as VTOL Capable Aircraft (VCA). Accordingly, the acronym VCA has also been used in this AC when referencing these aircraft types.

2.1.5.2 However, this AC is intended to provide guidance on aerodrome facilities that can accommodate both helicopters and VCA. Given this the term vertical flight aircraft will be used to mean both helicopters and VCA.



Figure 1: AW 139 helicopter at Karratha Airport (Image: CASA Media Library) and the Wisk Generation 6 (Image: Wisk)

2.2 Defining the operations

2.2.1 Intended vertical flight aircraft operations

2.2.1.1 Aerodrome operators should understand what the intended aircraft operations are for their aerodrome, including vertical flight capabilities. Intended aircraft operations refers to specific planned activities that aircraft will undertake while operating at a particular aerodrome. This includes details such as the:

- a. Type of operating aircraft. The size and type of aircraft the facility will be used by (current or future use by fixed wing, helicopters or other rotary aircraft, other forms of aircraft, turbine, piston, electric or other forms)
- b. Types of aircraft operations. The nature of flights (For example, take-off, landing, ground taxi, air-taxi, ground handling etc.).
- c. Classification of operations. Air transport (including passenger, cargo and medical transport operations), aerial work general and emergency service operations, private, training or itinerant.
- d. Flight schedules. Timetables for arrivals and departures, scheduled and unscheduled, of airlines and other aerodrome users.
- e. Manoeuvring area use. Designated runways, FATO's and associated landing sites and taxi paths for specific departure and arrival operations
- f. Weight and performance limitations. Adhering to the limitations advised by the aerodrome operator based on aircraft weight and performance characteristics to ensure safety.
- g. Regulatory compliance. Part 91 of CASR general operating and flight rules including compliance with air traffic control (ATC) instructions and airport operating instructions.
- h. Safety protocols. Implementing safety measures for all operations involving aircraft and the aerodrome.

Note: Intended aircraft operations refers to the operational planning and logistics for aircraft activities at a specific location to ensure safety, efficiency, and adherence to aviation regulations.

2.2.2 Design vertical flight aircraft

2.2.2.1 The design vertical flight aircraft¹ influences the physical characteristics and obstacle limitation surfaces for the vertical flight facilities.

2.2.2.2 The design vertical flight aircraft is a virtual aircraft composed of the most demanding physical and operational characteristics of all the intended vertical flight aircraft expected to

operate at the aerodrome including, but not limited to, the:

- largest set of dimensions, for example, D, rotor diameter (for helicopter)/maximum width (for VCA)
- greatest maximum take-off weight/mass (MTOW/MTOM)

most critical flight path requirements, that is, approach/climb-out gradient and/or horizontal flight requirements following a critical failure.

Note: For detailed explanation of the methodology behind the determination of the critical characteristics of the design aircraft concept refer to Appendix A to Chapter 3 of Doc 9261 - Heliport Manual from ICAO.

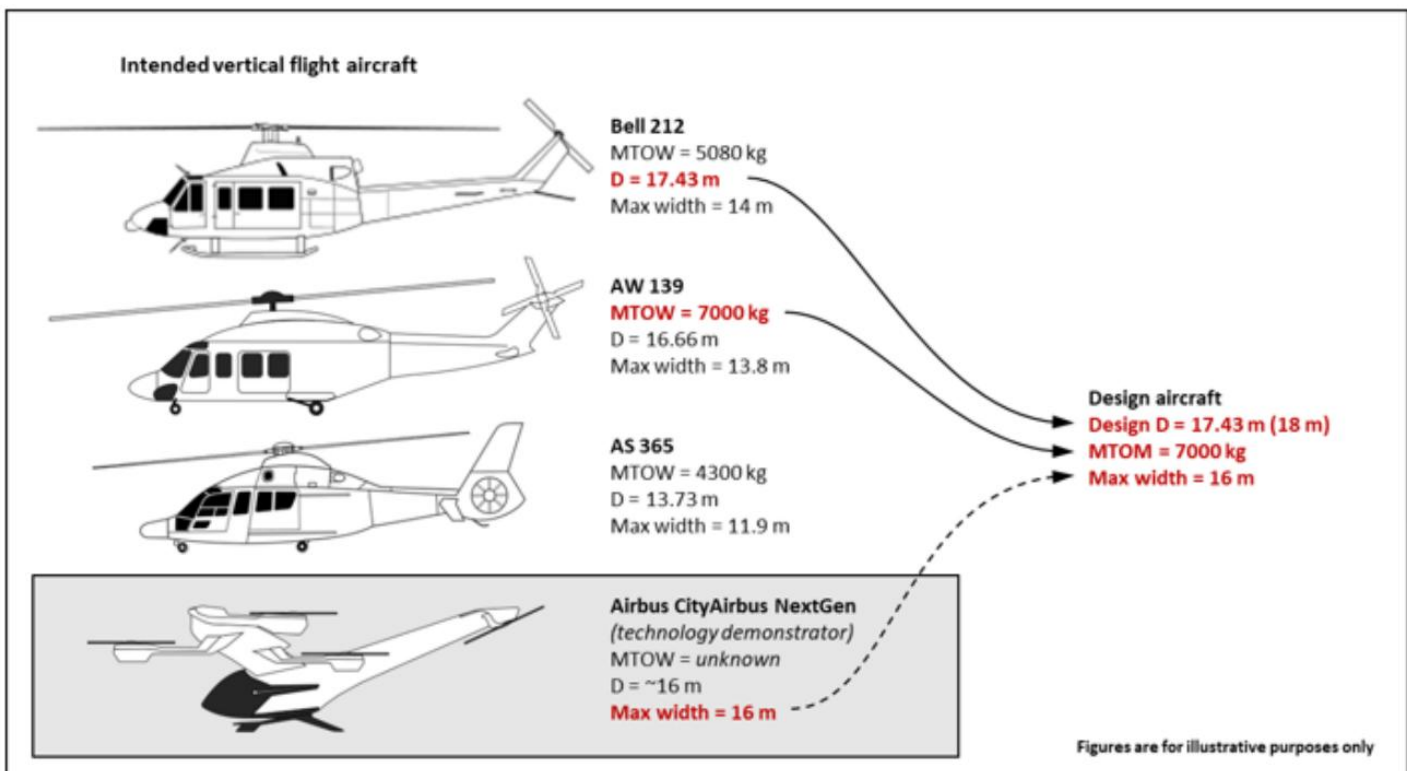

Figure 2: Compiling the design vertical flight aircraft data (source: CASA)

Determining design vertical flight aircraft (Figure 2)

The aerodrome operator determines the vertical flight aircraft with the largest D dimension, they intend to accommodate is a Bell 212 helicopter. A Bell 212 helicopter has a D of 17.43 m, therefore the design vertical flight aircraft has a (design) D of 17.43 m.

The heaviest vertical flight aircraft is determined to be a Leonardo AW139 at 7,000 kg (but which only has a D of 16.6 m) then the design vertical flight aircraft retains the D from the Bell 212 but

has the maximum take-off weight of the AW139.

The AS 365, having a D, a width and a take-off weight less than the other 3 vertical flight aircraft does not influence any of these 3 aspects of the design vertical flight aircraft specifications.

The aerodrome operator should consider all vertical flight aircraft to determine which may have the most critical flight path requirement.

The addition of the CityAirbus NextGen (as an example VCA) which reportedly has a max width and D of approximately 16 m, would provide the design vertical flight aircraft with a max width of 16 m, while the design D would still be 17.43 m.

Note: Additional considerations for design vertical flight aircraft may include undercarriage width, landing distance requirements, rejected take-off distance requirements and the impact of DW/OW when vertical flight aircraft are landing, manoeuvring on the aerodrome or at takeoff. Contingency planning for future larger aircraft should also be considered.

2.2.3 Downwash and outwash

2.2.3.1 As the size of helicopters increases downwash and outwash (DW/OW) hazards have become a concern across the industry. The potential for DW/OW from AAM aircraft is becoming understood as testing of these aircraft continues as part of their certification program. The hazards and risks vertical flight aircraft introduce during certain operations at facilities designed for aeroplanes may not have been sufficiently considered in an aerodrome context. Accordingly, the airborne movement of vertical flight aircraft over facilities designed for aircraft to ground manoeuvre may introduce unassessed risk. Early indications are that certain VCA may introduce more significant DW/OW hazards than the DW/OW hazards of helicopters.

2.2.3.2 In recent years, the Air Transport Safety Bureau (ATSB), and other foreign aviation investigation agencies, have recorded a number of incidents associated with DW/OW, many being associated with the increased operating weight of helicopters being used now in medical retrieval services.²

2.2.3.3 The hazards of DW/OW may vary significantly depending on:

- the operating weight of the helicopter or VCA
- rotor or propeller blade sizes, designs and rotational speeds
- the disk loading of the vertical flight aircraft
- the ambient temperature at the aerodrome
- the velocity and direction of ambient wind

- disruption to airflow caused by terrain, structures and buildings
- gradient of approach and departure paths flown by vertical flight aircraft.

Helicopter Downdraft Danger. (BP Video produced by BP)

'The video explains the dangers of helicopter downdraft when a helicopter is near an offshore installation. It shows the areas most affected by downdraft and provides steps that installations can

2 ATSB Transport Safety Report AD-2022-001 - Safety risks from rotor wash at hospital helicopter landing sites – 27 September 2023 (see <https://www.atsb.gov.au/sites/default/files/2023-09/AD-2022-001-Final.pdf>)

take to reduce the risks during helicopter arrivals and departures. Following these steps helps make helicopter operations safer and minimizes potential dangers.'

Transcript available in the video.

2.2.3.4 When siting any vertical flight facilities on an aerodrome, the aerodrome operator and/or aerodrome designer should consider the effect of DW/OW and where required include a protection zone that is appropriate to the design vertical flight aircraft.

2.2.3.5 Section 2.2.3 of both AC 139.R-01 and AC 139.V-01 have specifications on DW/OW and considerations as they relate to heliports and vertiports respectively. The specifications in both ACs are equally applicable to vertical flight facilities on an aerodrome.

2.2.3.6 Section 2.2.3 of both AC 139.R-01 and AC 139.V-01 have specifications on DW/OW and considerations as they relate to heliports and vertiports respectively. The specifications in AC 139.R-01 are equally applicable to vertical flight facilities on an aerodrome.

2.2.3.7 AC 139.R-01 introduced the concept of the DPZ. Areas that have been risk assessed as requiring a DPZ (such as the area around FATOs and under flight paths) should have controls put in place to ensure that risk to persons and property is reduced to an acceptable level.

2.2.3.8 The downwash and outwash protection zone (DPZ) should recognize that, in addition to the hover over the FATO, DW/OW will be prevalent during the final approach to the hover as well as, the initial lift-off, and whenever the vertical flight aircraft is positioning to, or away from, the FATO.

2.2.3.9 The area(s) that should be assessed for requiring a DPZ being at least:

- a. the area 3 x the max width (of the design vertical flight aircraft with the most critical DWOW risk³) around the FATO (measured from the edge of the FATO) see Figure 3.
- b. the area within 3 x the max width laterally of the vertical flight aircraft approach and departure tracks

c. any other areas that may be affected, such as taxi routes and vertical flight aircraft training areas.

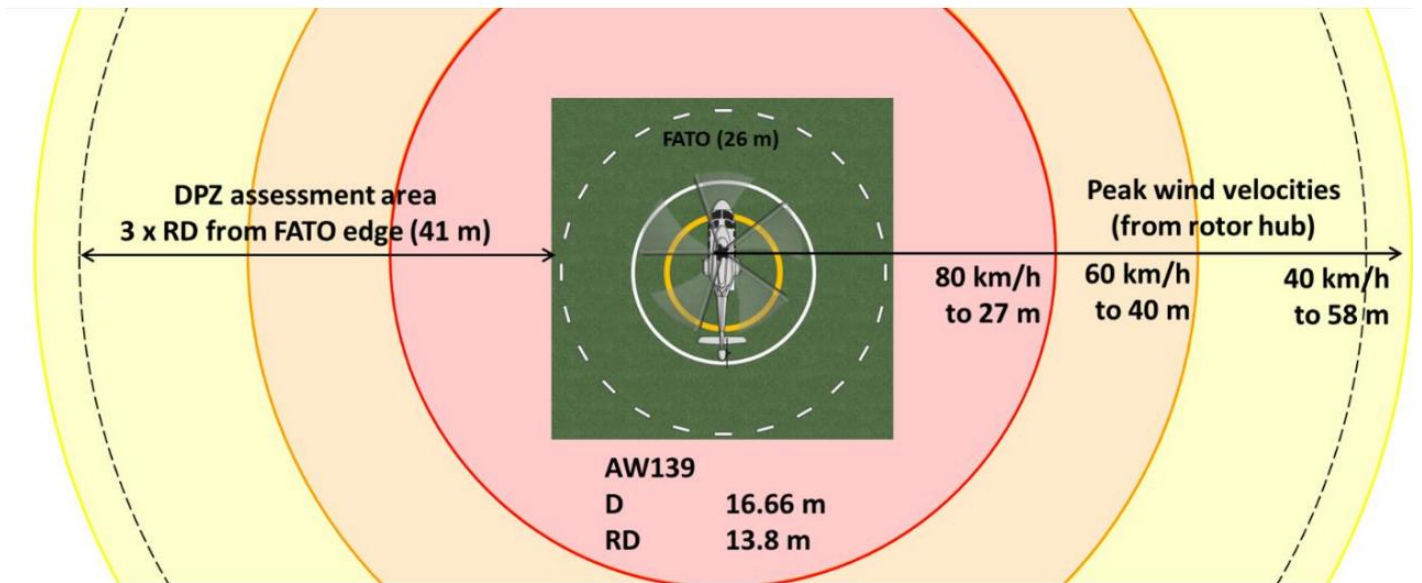

Figure 3: DPZ verses the peak wind velocity data for a AW139 (source: CASA)

3 Determined by the data in Table 1 in Appendix A of AC 139.R-01. This table is exhaustive so similar data provided by the aircraft manufacturer, ICAO or other State civil aviation authorities should also be considered.

Note: ICAOs Doc 9261 (from sixth edition on) provides guidance information on the maximum DW/OW velocities as concluded by Ferguson, 'Rotorwash Operations Footprint Modelling'. This data is included in AC 139.R-01. All diagrams illustrating peak wind velocities in this AC are based on this data.

The UK CAA CAP 30754 (April 2025) builds on industry's understanding of downwash and outwash highlighting that the effects of DW/OW should not be thought of as a constant air flow at any single point. But is instead a turbulent, buffeting and unpredictable movement of air with the potential for sudden changes in speed and direction of air flow.

Aerodrome specific downwash and outwash considerations

2.2.3.10 Aerodrome operators should consider the DW/OW hazards of vertical flight aircraft operations during all phases of flight operations within and around the aerodrome including:

- approach and climb-out manoeuvres
- liftoff and touch down within a FATO/TLOF, a stand or on an apron

- ground taxiing
- air-taxiing, air transit

Approach and climb-out manoeuvres

2.2.3.11 Approach and climb-out paths should be considered as they relate to the layout of facilities within the aerodrome. Approach and climb-out paths that pass over taxiways, taxi lanes or aprons could pose a DW/OW hazard to aircraft or vehicles on the ground or personnel on the aprons.

2.2.3.12 Aerodrome operators should also consider the impact of approach and climb-out paths that cross the aerodrome boundary and their impact on non-aeronautical facilities, people and publicly accessible areas.

Lift-off and touch down within a FATO/TLOF, a stand or on an apron

2.2.3.13 When vertical flight aircraft lift-off and touchdown, they require a large amount of power to decelerate to the hover and hover, or to become airborne, establish a hover and manoeuvre for taxi or departure.

Ground taxiing

2.2.3.14 Helicopters, with wheeled undercarriages, capable of ground taxiing, create significantly less DW/OW when ground taxiing compared to when they are air-taxiing and they should be capable of ground taxiing on a taxiway with a taxiway strip code consistent with the helicopter's rotor width.

Air taxiing

2.2.3.15 Skid-equipped helicopters, being unable to ground taxi, will have no option but to either air-taxi or air transit between a FATO and parking position. Aerodrome operators should consult with helicopter operators (and air service providers where applicable) to determine air taxi and air

4 CAP 3075 - Protecting the Future: Trials and Simulation of Downwash and Outwash for Helicopters and Powered Lift Aircraft. www.caa.co.uk/CAP3075

Guidelines for vertical flight aircraft facilities at aerodromes designed for aeroplanes

transit routes around the aerodrome that pose the least DW/OW risk to facilities, aircraft, vehicles and persons. Refer to 6.1.6 of this AC for publishing air taxi routes.

2.2.3.16 Air-taxi routes above apron taxilanes, directly over light aircraft parking or areas where people may congregate should be avoided.

2.2.3.17 Air taxi routes, where a helicopter remains in ground effect, can present a DW/OW hazard to adjacent facilities including, but not limited to, runways or aprons. Figures 4 and 5 illustrate helicopters air-taxiing over a taxiway with the potential peak air velocities overlaid.

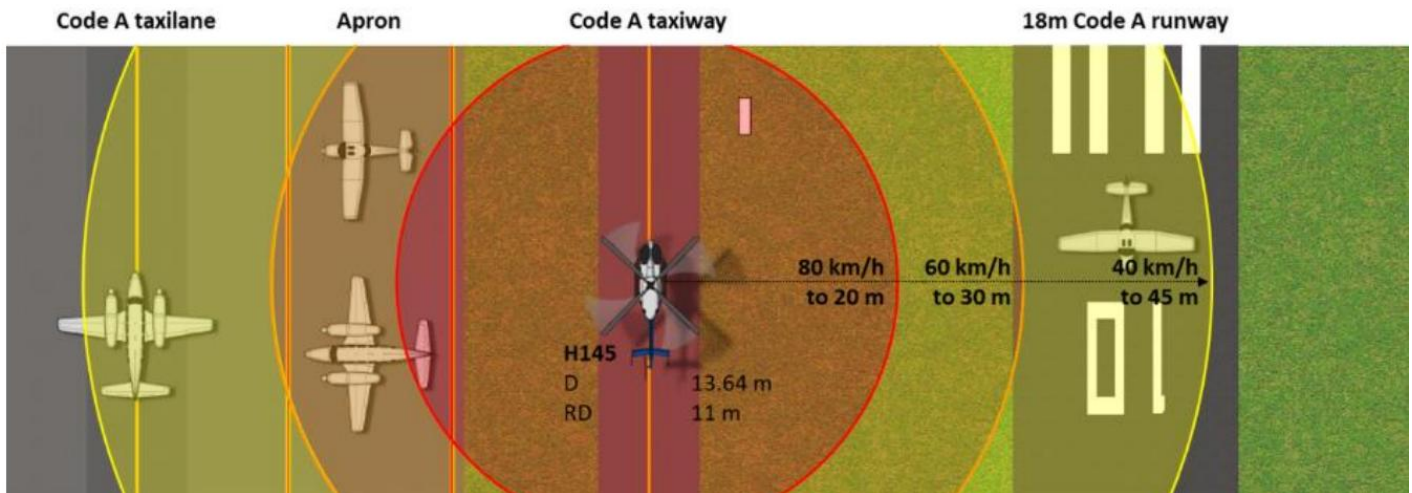

Figure 4: H145 peak wind velocities vs code A separations (source: CASA)

2.2.3.18 Figure 4 shows an at scale overlay of potential peak wind velocities of a H145 helicopter airtaxiing along a code A taxiway with aprons and a code A runway at minimum separation distances as per the Part 139 MOS.

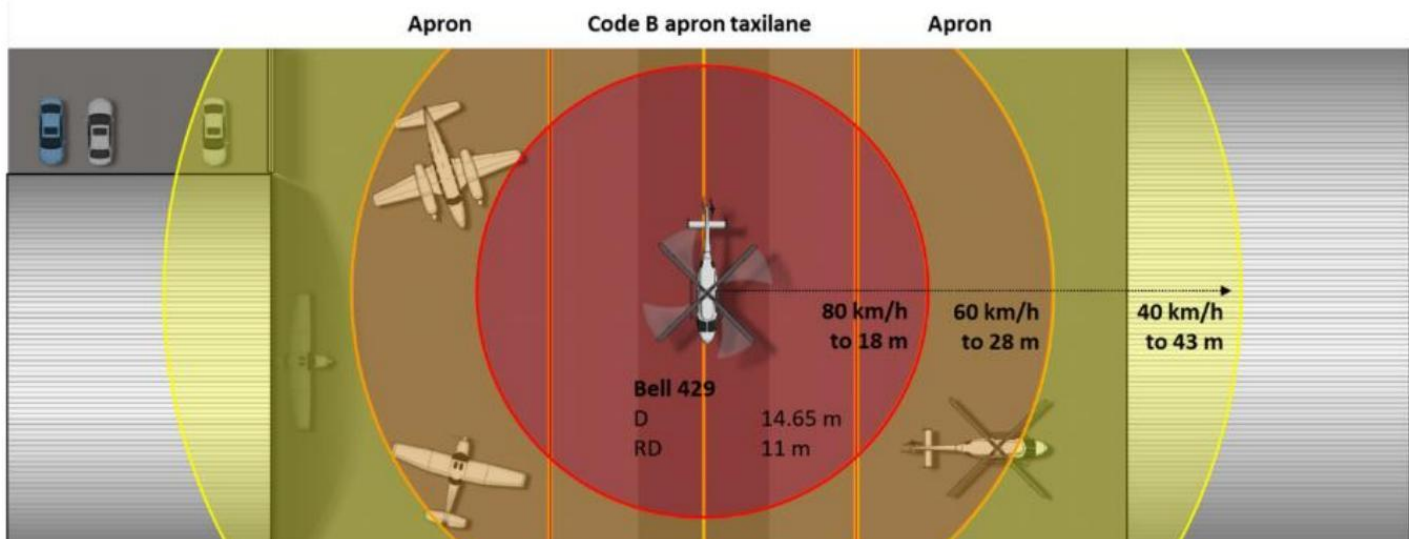

Figure 5: Bell 429 peak wind velocities vs code B separations (source: CASA)

2.2.3.19 Figure 5 shows an overlay of potential peak wind velocities of a Bell 429 helicopter airtaxiing along a code B taxilane with aprons minimum separation distances as per the Part 139 MOS.

Note: Figure 4 and Figure 5 show the potential peak wind velocities while in ground effect based on the data as published in AC 139.R-01. This suggests that, in both scenarios, aircraft parked on the aprons may be subject to peak wind velocities of 80 km/h, and in Figure 4, that an aircraft on a parallel code A runway could be subject to wind velocities of 40 km/h or more.

2.3 Arrival and departure procedures

2.3.1 The pilot in command of an aircraft is required to join the circuit pattern of an aerodrome for a landing or after take-off. However, AIP ENR 1.1 permits the pilot of a helicopter at a noncontrolled aerodrome, as an alternative to joining standard circuit procedures, to join the circuit area from any direction, at 500 ft above the surface, and descend to land or take-off from any location the pilot assesses as suitable.

2.3.2 The operator of an aerodrome has a responsibility for safety considerations on their aerodrome, and as such may not allow helicopter pilots to approach, taxi and land or take-off at their own discretion.

2.3.3 Part 139 MOS Chapter 5 requires an aerodrome operator to publish aerodrome operational procedures including standard taxi routes, special procedures and notices determined by the aerodrome operator that relate to the safe use of the aerodrome.

2.3.4 An aerodrome operator (in consultation with ATC at a controlled aerodrome) may choose to specify special procedures to be used by vertical flight aircraft operators when conducting arrivals, departures, final approaches, take-offs and ground manoeuvring.

2.3.5 Such special procedures may require vertical flight aircraft to join the runway in use following the standard traffic pattern or alternative arrangements, such as to a taxiway or taxiway intersection parallel the traffic pattern, or to a standalone FATO.

2.3.6 Aerodrome operators, in consultation with aircraft operators and air traffic services, should conduct an airspace hazard safety assessment⁵ before considering the option of vertical flight aircraft operations that would have a different or modified traffic pattern compared to the established generic procedures for vertical flight aircraft operations.

Caution: Helicopter wake turbulence

DW/OW hazards are generally related to helicopters hovering or moving at relatively slow speeds, nominally less than 15 kts.

However, at ground speeds greater than effective transitional lift, usually 16-20 kts, DW/OW effects trail the helicopter and presents as wake turbulence vortices with potentially significant effects on aircraft adjacent to the helicopter flightpath track and following the helicopter.

The VAI (formally the HAI) and the FAA recommend that fixed wing aircraft pilots and operators recognise this risk and adopt the 3-3-2 separation rule when interacting with helicopter operations, regardless of helicopter mass:

- 3 rotor diameters lateral separation at hover
- 3 nautical miles trailing separation
- 2 minutes wait time separation.

Caution! Helicopter Wake Turbulence (The Rotorcraft Collective) Video by the FAA

'Helicopters can generate wake turbulence that is equally as hazardous as fixed-wing aircraft. You should avoid operating aircraft within three rotor diameters of any helicopter in a slow hover taxi or stationary hover and use caution when operating behind or crossing the path of a landing and departing helicopter. Watch this video for more tips on avoiding helicopter wake turbulence.'

Transcript available in the video.

2.3.7 Simultaneous landing and/or take-off operations - helicopters

2.3.7.1 Where there are simultaneous operations, a helicopter will generate significantly more wake turbulence than a fixed wing aircraft of the same weight.

2.3.7.2 For simultaneous use, a non-instrument runway and non-instrument FATO, the minimum separation distance between the runway centreline and FATO centre (or extended centreline) should be as described in Table 10 below.

Table 10: Recommended separation distances between non-instrument FATO and runway centrelines for simultaneous operations

Aeroplane size	Small Helicopter ≤ 3175 kg	Medium Helicopter 3176 kg - 5670 kg	Large Helicopter > 5670 kg
Small aeroplane ≤ 5670 kg	90m	150m	210m

Large aeroplane 5670kg-100000 kg	150m	150m	210m
Heavy aeroplane >100000 kg	210m	210m	210m

2.3.8 Non-simultaneous landing and/or take-off operations - helicopters

2.3.8.1 Where existing FATOs and runways are located less than the above recommended separation distance, simultaneous operations between the FATO and runway should not be permitted.

2.3.8.2 At an uncontrolled aerodrome where medium and large helicopters and LIGHT⁶ wake turbulence category aircraft (7,000 kg or less) are arriving to FATOs and runways located less than the above recommended distance, aerodrome operators should consider providing published information advising LIGHT category aircraft of the helicopter wake turbulence hazard.

2.3.8.3 Aerodrome operators should consider that pilots of LIGHT wake turbulence category aircraft may not be aware that a preceding helicopter may pose a wake turbulence hazard.

⁶ A LIGHT turbulence category refers to aircraft types with and MTOW of 7 000 or less. Further details on wake turbulence and wake turbulence categories can be found in AC 91-16 on the CASA website.

Example:

For the fictional aerodrome depicted, where approaches to RWY 22 and the northern FATO are separated by less than 21 m, the ERSA entries might read:

Aircraft 7,000 kg and below arriving RWY 22 behind a helicopter arriving to northern FATO, caution helicopter wake turbulence.

EXAMPLE ONLY

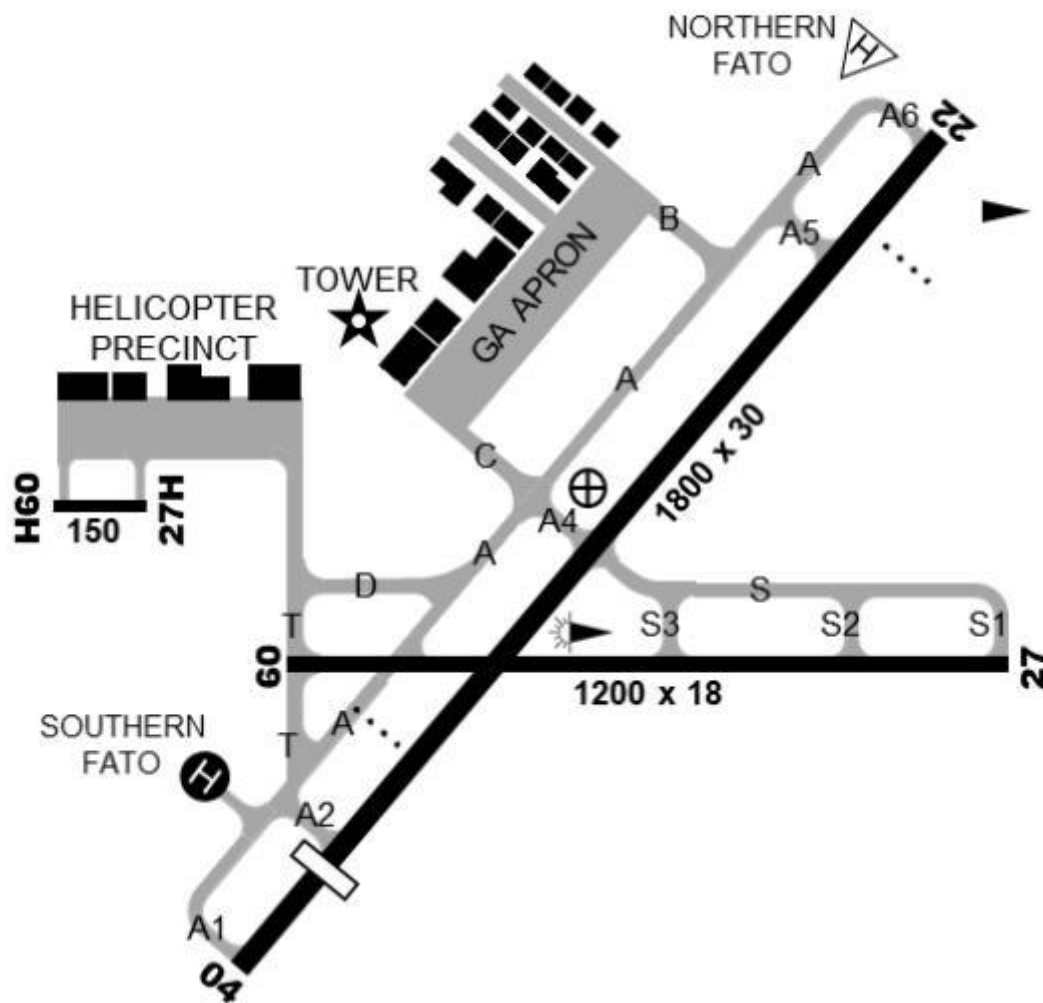

Note:

ATC services are not required to provide a wake turbulence separation standard between LIGHT category aircraft and helicopters less than 7,000 kg MTOW.

If an aerodrome, with ATC tower services, wishes to have helicopter wake turbulence separation standards provided between helicopters 7,000 kg and below and LIGHT category aircraft, then this would have to be by local arrangement with Air Services Australia.

2.3.9 Simultaneous landing and/or take-off operations - VCA Reserved.

2.3.10 Non-simultaneous landing and/or take-off operations - VCA Reserved.

3 Physical characteristics of aerodrome vertical flight facilities

3.1 General

3.1.1 The physical facilities that vertical flight aircraft use may be runways, taxiways, and aprons that have been designed and provided for aeroplanes. However, an aerodrome operator may choose to design and build facilities on their aerodrome specifically for vertical flight aircraft.

3.1.2 Vertical flight aircraft may be integrated with aeroplanes on some facilities and segregated from aeroplanes on other facilities.

3.1.3 These specific facilities may include (illustrated by figure 6):

- a. one or more final approach and touchdown areas (FATO)
- b. one or more touch down and lift-off areas (TLOF)
- c. FATO protection areas
- d. taxiways and/or taxi-routes
- e. stands (and associated protection areas).

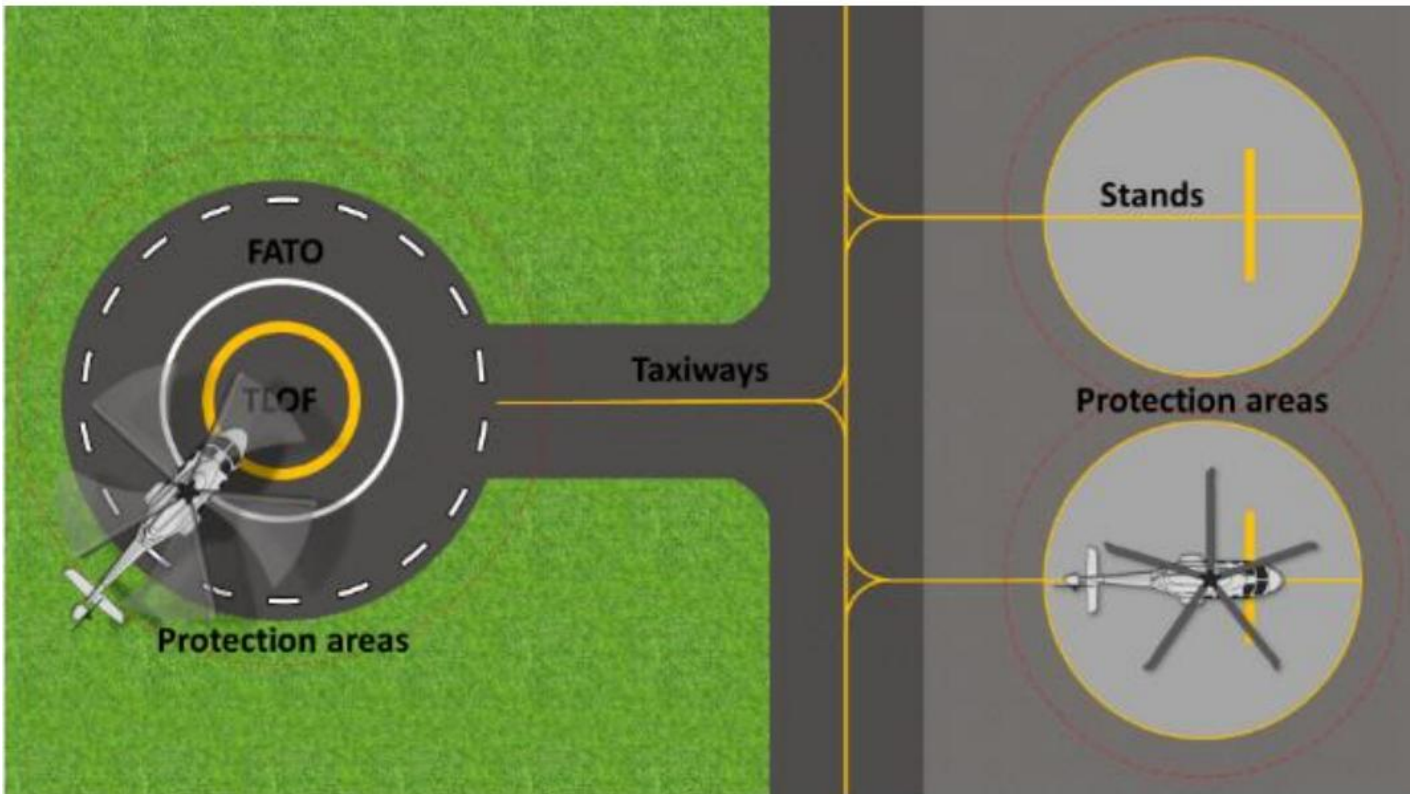

Figure 6: Example of facilities that may be required for vertical flight operations at an aerodrome (Source: CASA.)

Note: Refer to AC 139.R-01 for the detailed specifications for facilities covered in this chapter.

3.1.4 Design consultation

3.1.4.1 Aerodrome operators and aerodrome designers should design vertical flight facilities in consultation with relevant stakeholders. The design development should include a consultation with relevant stakeholders throughout the life of the project, such as but not limited to:

- CASA
- Air Services Australia
- aircraft operators (both fixed wing and vertical flight operators)
- vertical flight aircraft original equipment manufacturers (OEM)
- local governments
- State, territory and federal government agencies

3.2 Physical facilities

3.2.1 The FATO, the TLOF, the safety/protection areas and the touchdown positioning marking (within the TLOF) each have a defined purpose and as such interact with each other in a particular way.

FATO

3.2.2 The purpose of the FATO is to provide an area that will safely contain the whole vertical flight aircraft during the final moments of the approach to hover and the initial take-off manoeuvres from hover. Where the FATO is to provide for rejected take-off then the FATO should provide a surface capable of supporting and containing an aircraft, performing a rejected take-off, until it comes to a stop.

TLOF

3.2.3 The TLOFs purpose is to provide a dynamic load bearing area that will safely contain the undercarriage (wheeled or skid-equipped) of a vertical flight aircraft during touch down and liftoff manoeuvres.

FATO protection area (safety area)

3.2.4 The FATO protection area (FPA) provides an area clear of obstacles (other than essential navigation aids). The FPA provides an area to protect against the risk of obstacle intrusion that may affect the safe operation of aircraft where the vertical flight aircraft deviates from the bounds of the FATO during approach, take-off or hover.

3.2.5 The purpose of the safety/protection area is to protect the aircraft and its operation. The safety/protection area is not intended to protect people and equipment from the effect of the aircraft or its operation.

The touchdown positioning marking

3.2.6 The facility that ties the others together is the touchdown positioning marking (TDPM). The TDPM is provided to give the pilot of vertical flight aircraft guidance to accurately and safely touch down. Touching down with the pilot's seat over the TDPM ensures the aircraft undercarriage is located safely within the TLOF and the whole aircraft is positioned within the FATO or aircraft stand and clear of adjacent obstacles.

3.3 Final approach and take-off area

3.3.1 An aerodrome that has vertical flight operations should have at least one location nominated to serve as the FATO area.

3.3.2 A FATO at an aerodrome may be a runway, a nominated taxiway or taxiway intersection or a purpose-built facility.

3.4 Nominating a runway or taxiway as a FATO

3.4.1 A runway or taxiway nominated as a FATO should consider the additional specifications for a FATO outlined in section 3.1 of AC 139.R-01, such as but not limited to:

- being free of obstacles
- resistant to the effects of DW/OW generation by the aircraft
- have the pavement strength capable of withstanding the intended (if provided with a TLOF) and unintended (to contain a rejected take off or forced landing) landing forces
- be of a length and width appropriate to the performance class of the intended aircraft operation
- have an associated protection area.



Figure 7: Robinson helicopter approaching Runway 29C at Bankstown Airport (Source: CASA)

3.4.2 Where a taxiway intersection is nominated as a FATO the approach and departure paths available to that FATO should, where practicable, be considered so that an approaching or departing vertical flight aircraft does not need to over fly aircraft that may be on nearby taxiways. Refer Figure 8.

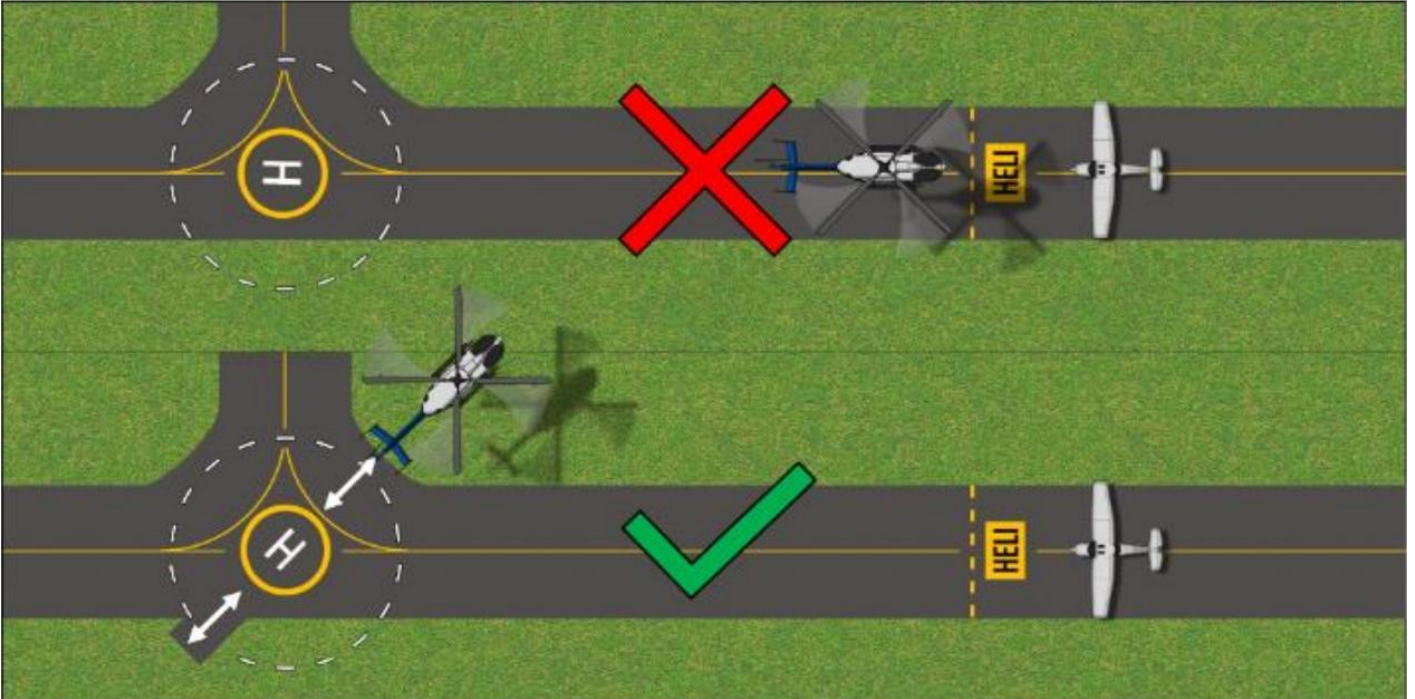

Figure 8: Alignment of approach and departure paths for a taxiway FATO to deconflict with other traffic on the taxiway (Source: CASA)

3.4.3 Standalone FATOs

3.4.3.1 If an aerodrome wishes to have a FATO (or multiple FATOs) that are separate facility(s) that are for the exclusive use of vertical flight aircraft, then there are 2 types of FATOs that may be considered. A runway type or a conventional (non-runway) type.

3.4.3.2 The size of the FATO is usually determined by the length of the rejected take-off distance required by the aircraft operator, where provided for and the design vertical flight aircraft which is the most demanding helicopter or VCA intended to operate at the aerodrome.

Runway type FATO

3.4.3.3 Where the runway cannot be used as a FATO, and a vertical flight aircraft operator requires their aircraft to perform a rolling take-off manoeuvre, or where the aircraft has a requirement for a longer RTODR than can be accommodated by an elongated FATO, the aerodrome operator may choose to provide a runway type FATO.

Note: From a design and marking perspective once the length of a FATO is greater than 5 times its width then a runway type FATO should be considered. The broken perimeter markings and the 'H' designation for a runway type FATO is intended to be a visual indication for a fixed wing pilot not to mistake it for a fixed-wing runway.

3.4.3.4 A runway type FATO should be designed to meet the specifications as outlined in section 3.1 of AC 139.R-01.

Guidelines for vertical flight aircraft facilities at aerodromes designed for aeroplanes

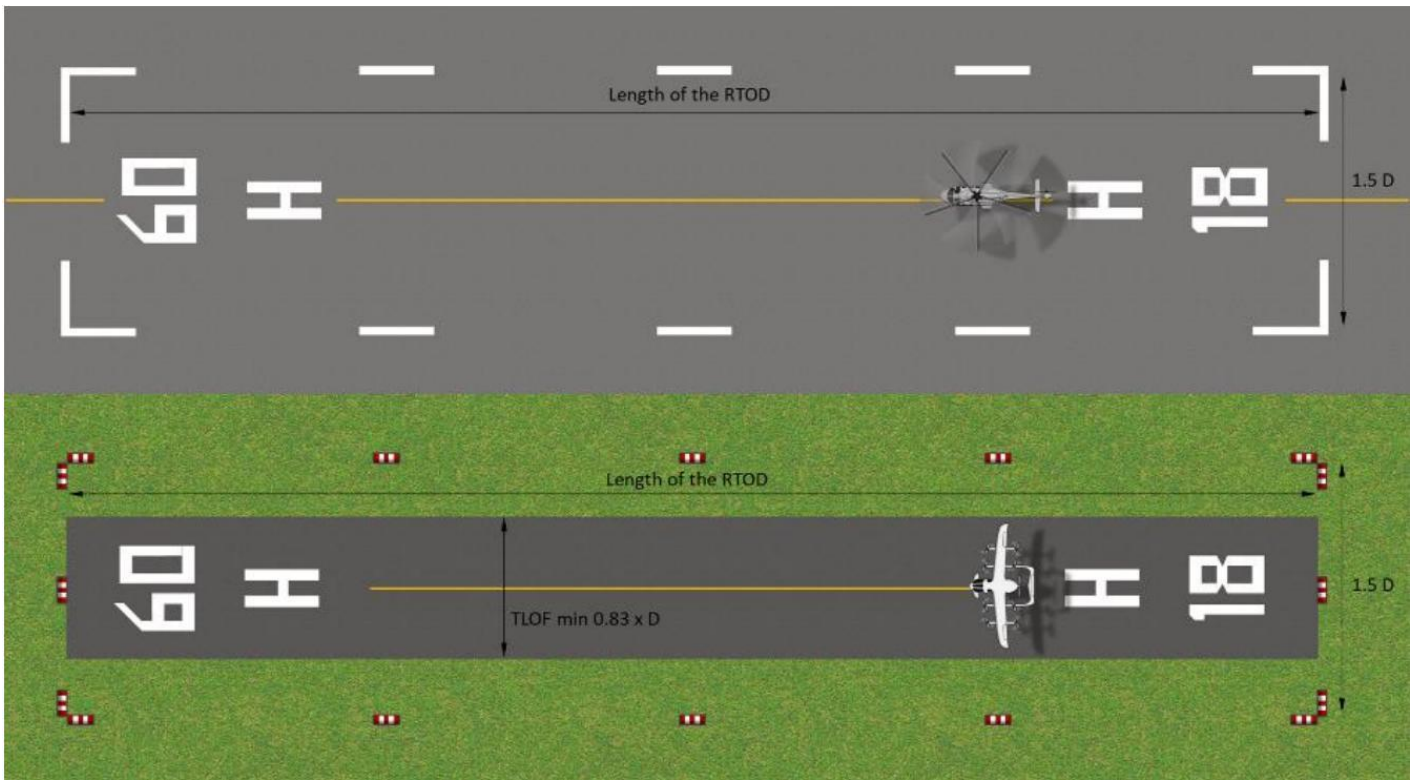

Figure 9: Runway type FATO examples (Source: CASA)

3.4.3.5 Figure 9 shows an example of 2 runway type FATOs. One co-located with an existing taxiway centreline, the other being a standalone facility with a grass FATO and paved TLOF.

Conventional FATO

3.4.3.6 The minimum dimensions of the FATO should be at least 1.5 x Design D or the length and width specified by the AFM for the design vertical flight aircraft.

Refer to section 3.1 AC 139.R-01 for specifications on FATO design, and Doc 9261 for detailed explanation of the derivation of the figures used for facility design.

Table 11: Size requirements of conventional (non-runway type) FATO?

Diameter FATO being provided	Largest vertical flight aircraft that can be accommodated	Maximum D value	Associated TLOF. $0.83 \times \text{Design D}$ (1 x D) ⁷
20m	H125/AS350, Bell 206, BK-117	13m	10.8 m (13 m)
25.5m	AW139, S-76D, H160. Most current VCAS [^]	17m	14.2 m (17 m)
30m	Bell 412 and 212, H215, H225, Bell 525	20m	16.6m (20m)
35m	S-92, AW101	23m	19.1m (23m)

7 Rounding up to $1 \times D$ can make calculations easier. $1 \times D$ TLOF is also used in guidance for elevated and offshore helidecks and in the FAA Vertiport Engineering Brief 105A.

8 Data on 11 leading VCA aircraft provided to ICAOs Vertical Flight Infrastructure Working Group by OEMs shows that a Design vertical flight aircraft derived from these aircraft would have a D of 16.9 m.

Guidelines for vertical flight aircraft facilities at aerodromes designed for aeroplanes

3.4.3.7 Table 11 is a general guide to FATO sizes and the helicopters and VCAs able to be accommodated on it, using the $1.5 \times$ design D calculation. Vertical flight aircraft smaller than the design aircraft can use larger sized FATOs

3.4.3.8 Also included in the table are the associated TLOF dimensions (both as $\min 0.83 \times D$ and a simplified $1 \times D$) where a TLOF is included.

Note: The certification requirements of individual aircraft and the way the aircraft are operated may vary the size of the FATO and associated TLOF. Certification requirements of individual helicopters and VCA intended to use the FATO that require a different size facilities greater than $1.5 \times D$ should be considered.

3.5 Aiming point or TLOF

3.5.1 The aerodrome operator should determine the intended operation to and from the FATO(s). The aerodrome operator should determine if the intended operation for the vertical flight aircraft is to touch down within the FATO, or alternatively, to approach to hover over the FATO then transition to an air-taxi or air transit to a TLOF, stand or apron elsewhere on the aerodrome.

3.5.2 Where an aerodrome operator permits vertical flight aircraft to touch down within the FATO, the FATO should contain a touchdown and lift-off area (TLOF) with relevant visual aids for a TLOF, including a TDPM.

3.5.3 Where a touch down within the FATO is not permitted, the FATO should contain an aiming point indicated by the relevant visual aids.

Note: Section 5 of this AC will cover the correct markings to be used for FATOs, TLOFs and aiming points.

3.5.4 Touch down and lift-off area

3.5.4.1 A touch down and lift-off area (TLOF) should meet the specifications for a TLOF outlined in section 3.1 of AC 139.R-01, such as but not limited to:

- being free of obstacles
- have the bearing strength capable of withstanding the intended (and unintended) landing forces
- resistant to effects of DW/OW generated by the aircraft
- have sufficient friction to avoid skidding.

3.5.4.2 The minimum size for a TLOF should be at least 0.83 x design D, or sized to sufficiently contain the undercarriage of the design vertical flight aircraft.

Note: Emerging research indicates a minimum of 1 x design D (or more) may be recommended for VCA operations. Aerodrome operators should consider a larger TLOF if intending to cater for VCA operations.

3.5.4.3 Aerodromes with natural surface TLOFs (or stands) may consider the use of ground surface reinforcement such as, grid type products to improve the bearing strength, surface friction characteristics and drainage of natural surface TLOFs where a paved surface is not viable or desired.

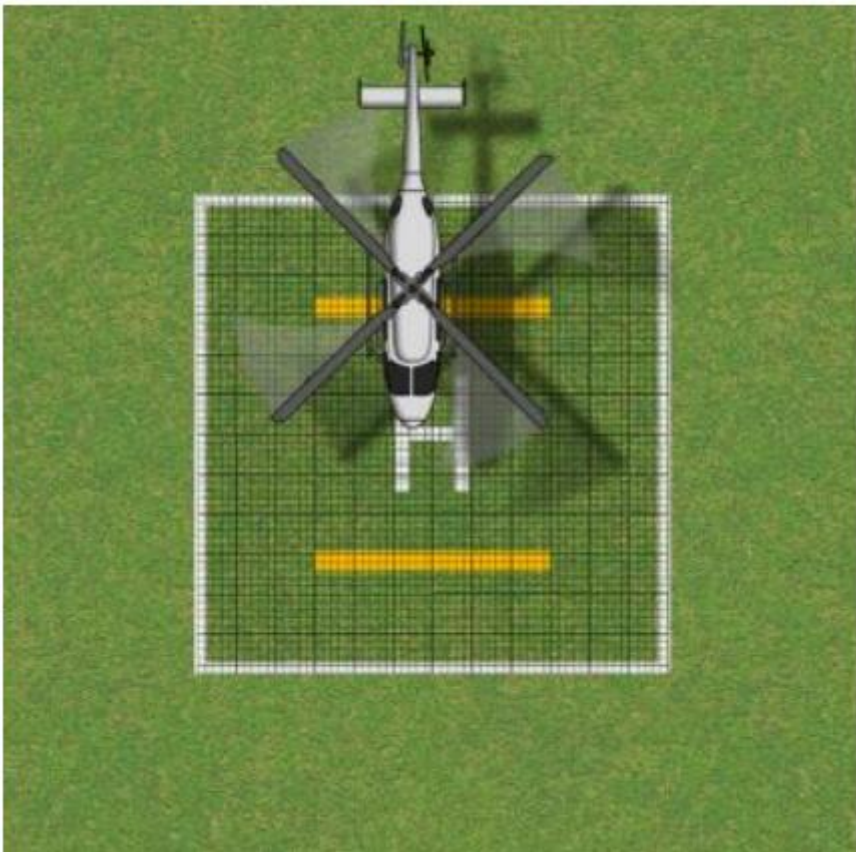



3.5.4.4 Figure 10 shows an example of a grass TLOF that has had grass reinforcing grid product installed to help improve the bearing strength of the natural surface.

3.5.4.5 Ground surface reinforcement products should be installed and maintained so they will not lift or move under the maximum downwash or dynamic loading of the design vertical flight aircraft.

3.6 Nominating taxi-routes and transit routes

3.6.1 Aerodrome operators that accommodate vertical flight aircraft, have 3 options for defining the paths along which vertical flight aircraft will manoeuvre. These are:

1. ground taxi-routes
2. air taxi-routes

or

3. air transit routes.

3.6.2 Aerodrome operators may nominate taxiways on the aerodrome that are or are not available for vertical flight aircraft to taxi on.

3.6.3 These nominated taxi routes should be part of an aerodromes published information and should be included in the aerodrome manual.

3.6.4 The aerodrome operator may choose to nominate aerodrome facilities for vertical flight aircraft due to the mitigation or elimination of potential hazards and risks specific to the intended operation of the aircraft.

3.6.2 Ground taxi-routes

3.6.2.1 Vertical flight aircraft with wheeled undercarriage may ground taxi. Similar to a propellor driven aircraft, once the aircraft is moving it requires little energy to maintain a ground taxi, as such the DW/OW effects are lessened.

3.6.2.2 Centred on a taxiway, a ground taxi-routes for vertical flight aircraft should be no less than of 1.5 times the overall width of the design vertical flight aircraft.

3.6.2.3 Despite paragraph 3.6.2.2, for a VCA that has a different configuration for taxiing, such as having their outboard lift/thrust units unpowered or folded/stowed and publish a separate dimension for taxiing (Dtaxiing), then that dimension may be used instead of maximum width or they may be permitted to operate as a fixed-wing aircraft using the taxiway code system from the Part 139 MOS.

3.6.2.4 The maximum width of the helicopter or VCA as mentioned in 3.6.2.2 should not exceed the permitted (fixed) wingspan for the taxiway or taxilane code.

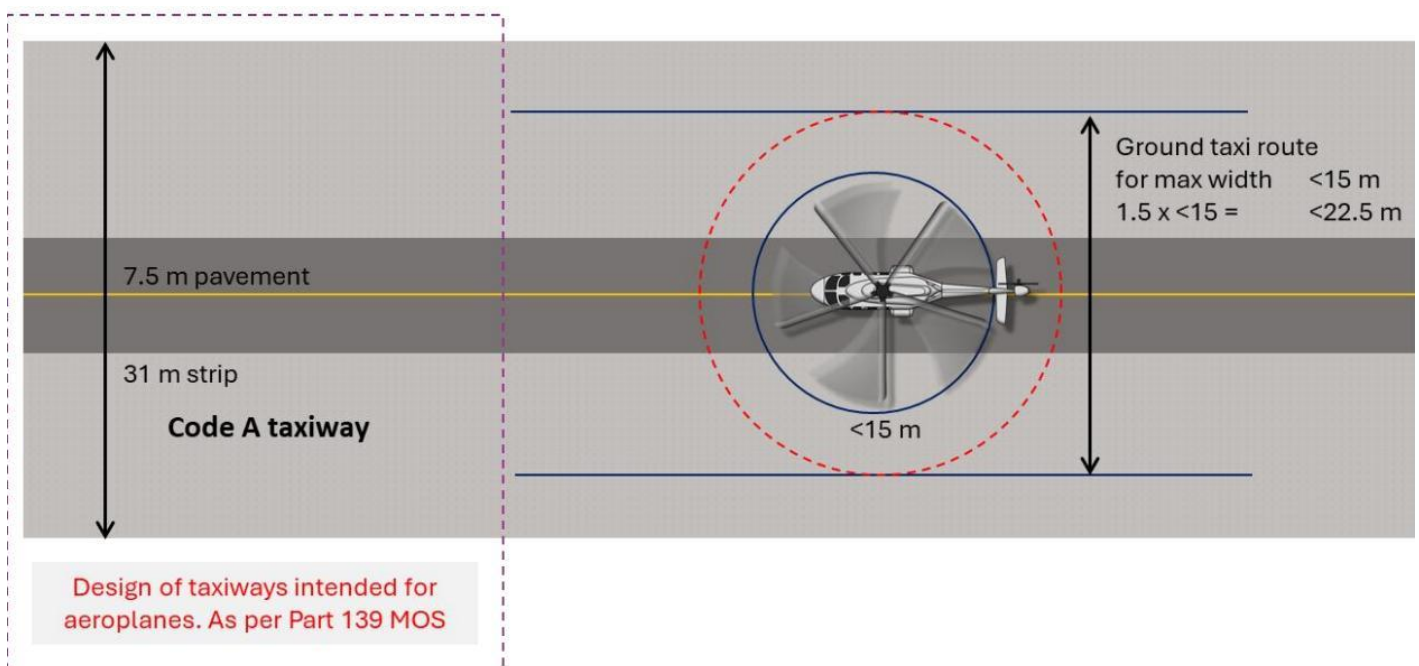

Figure 11: Illustration of a code A taxiway and taxiway strip vs the ground taxi route width for a helicopter of <15 m

Table 12 shows the relationship between taxiway and taxilane strip widths and the corresponding rotor widths that would contain the ground taxi-route requirements for vertical flight aircraft.

Table 12: Taxiway code strips vs ground-taxi route limitations

Taxiway/taxilane Code	Code A taxiway	Code B taxiway	Code A taxilane	Code B taxilane
Strip width (m)	31	40	24	33

Max. permitted wingspan (m)	<15	<24	<15	<24
Maximum overall width ⁹ for a groundtaxing helicopter or VCA (m)	<15	<24	<15	<24

3.6.2.5 While outwash is considerably less for a ground taxiing helicopter than for an air-taxiing one, the effects of outwash hazards on, people, equipment and structures should be still be considered. This is especially important where the outwash effects may extend beyond the boundary of the aerodrome, where non-aerodrome activities may be impacted by the hazard.

3.6.2.6 VCA operators may be required to tow their aircraft in lieu of taxi due to energy conservation needs. This might be from or to the FATO or TLOF or perhaps a taxiway close to a hanger or apron. Aircraft under tow and under the charge of a responsible person are not required to observe the clearances mentioned above.

3.6.2.7 Aerodrome operator should be prepared to liaise with VCA, and helicopter operators should they need to tow their aircraft.

3.6.2.8 Aerodrome operators should risk assess the towing routes for helicopters and VCA to ensure appropriate pavement widths and obstacle clearance for the towing equipment and other aircraft.



Figure 12: AW 139 helicopter ground taxiing, Karratha Airport (Source: CASA)

3.6.2.9 Where aircraft operators intend to land, take-off or move their aircraft on mobile platforms, the aerodrome operator should obtain a copy of the safety assessment from the aircraft operators use of the mobile platforms and ensure that the hazards and risks to other aerodrome users is appropriately considered.

3.6.3 Air taxi routes

3.6.3.1 Air taxi routes allow for helicopter movements at a height not more than 2 rotor diameters above the ground and at a speed less than 20 kts. Air taxiing at this height represents the upper level of the Hover In Ground Effect (HIGE) phenomenon where the maximum velocity of DW/OW winds may occur.

3.6.3.2 Air taxiing vertical flight aircraft may introduce hazardous effects in terms of DW/OW, which may vary significantly. The DW/OW hazards may be a risk to infrastructure, other aircraft, aerodrome personnel and the public

3.6.3.3 Helicopters air taxiing (in ground effect) and air taxi routes should not be located where the taxi route would pass over, or adjacent to, facilities that could be adversely affected by the DW/OW. Areas that may be affected by DW/OW include but are not limited to:

- aircraft parking positions
- apron operations
- passenger or public areas
- the movement area.

3.6.3.4 When designing or nominating an air-taxi route it should have a minimum width of twice the overall width of the design vertical flight aircraft.

Guidelines for vertical flight aircraft facilities at aerodromes designed for aeroplanes

3.6.3.5 The aerodrome operator should consider any change to intended, or actual operation or helicopters or VCA on the manoeuvring area, with particular attention given to common use facilities such as fuel facilities and parking areas. The potential for aircraft to be moved or disturbed by helicopters or VCA air taxiing in the vicinity of aircraft being refuelled or waiting to be refuelled increases the risk of injury or harm to those affected by the hazardous effects of DW/OW.

3.6.3.6 Table 12 shows the relationship between taxiway code strips and air-taxi route limitations. It also shows the maximum rotor widths for helicopter over Code B Taxiways, and both taxilanes will be less than the permitted wingspan.

Table 13: Taxiway code strips vs air-taxi route limitations

Taxiway	Code Ataxiway	Code Btaxiway	Code Ataxilane	Code Btaxilane
Strip Width (m)	31	40	24	33
Max. permitted wingspan (m)	<15	<24	<15	<24
Maximum overallwidth for an air-taxinghelicopter or VCA (m)	<15	20	12	16.5

Note: Table 12 only shows the minimum facility dimensions as per Part 139 MOS vs the guidance for taxi route clearance in AC 139.R-01. These figures only provide protection for the helicopter and do NOT consider the hazardous effects of DW/OW or helicopter wake turbulence to people, facilities, other aircraft or aerodrome operations.

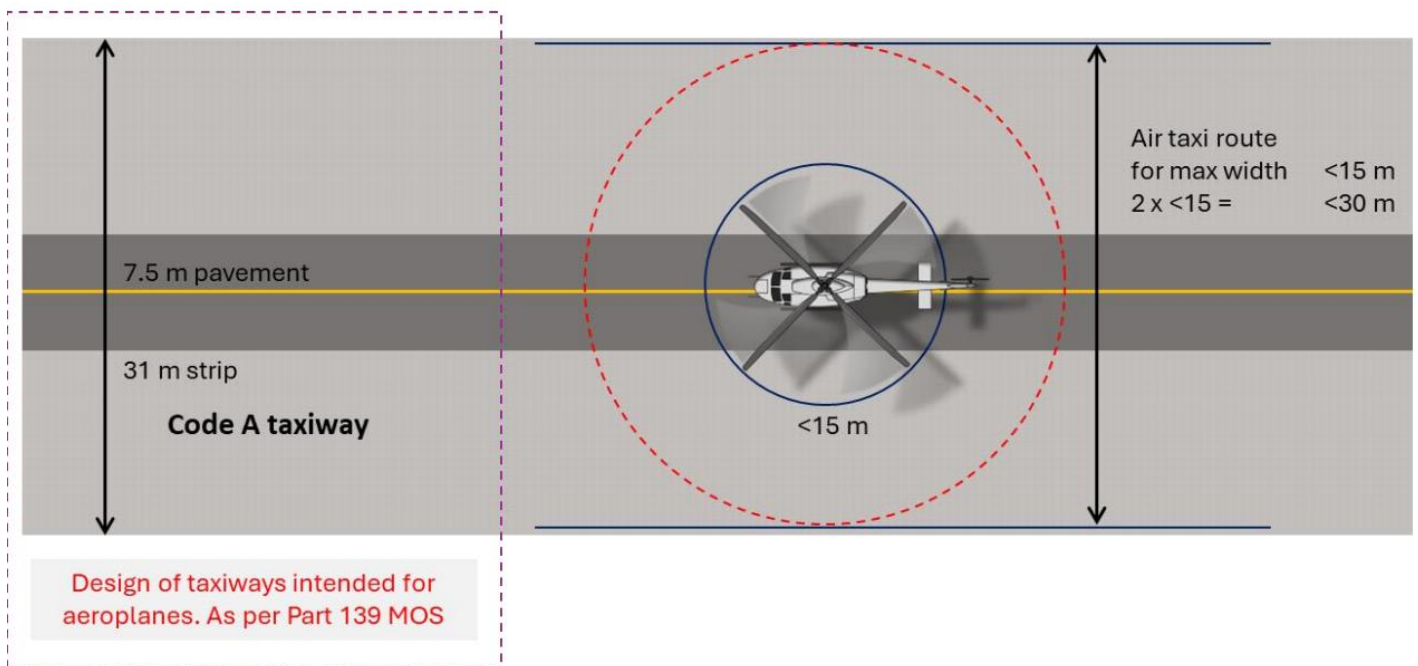

Figure 13: Code A taxiway dimensions vs air-taxi routes (Source: CASA)

3.6.3.7 Figure 13 shows an illustration of a code A taxiway and taxiway strip vs the air taxi route width for a helicopter with a max width of <15 m.

3.6.3.8 Table 14 shows the relationship between taxiway code strips and air-taxi route limitations where there are parallel taxiways and taxilanes. The table shows that the maximum overall widths for vertical flight aircraft over all parallel taxiway and taxilanes will be less than the permitted wingspan.

Table 14: Parallel taxiway separation vs air-taxi route limitations

Parallel Taxiways	Code Ataxiways	Code Btaxiways	CodeAtaxilanes	Code Btaxilanes
Centre line separation	23	32	19.5	28.5

Max. permitted wingspan (m)	15	24	15	24
Maximum overall width for an air-taxiing helicopter or VCA (m)	11.5	16	9.75	14.25

Note: Although the above information demonstrates helicopters and VCA may air taxi on taxiways designed for aeroplanes, albeit with reduced maximum rotor spans, when operating independently and when an aeroplane is operating on parallel taxiways or taxilanes, the gear deviation and increment required in the taxiway separation is halved. To minimise the risk, rotor span, aeroplane wingspan limitations or dependent aircraft operations may need to be considered in the context of operational requirements.

Figure 14 and Figure 15 illustrate the current disparity between the design specifications for parallel taxiway and taxilane design and air-taxi route design.

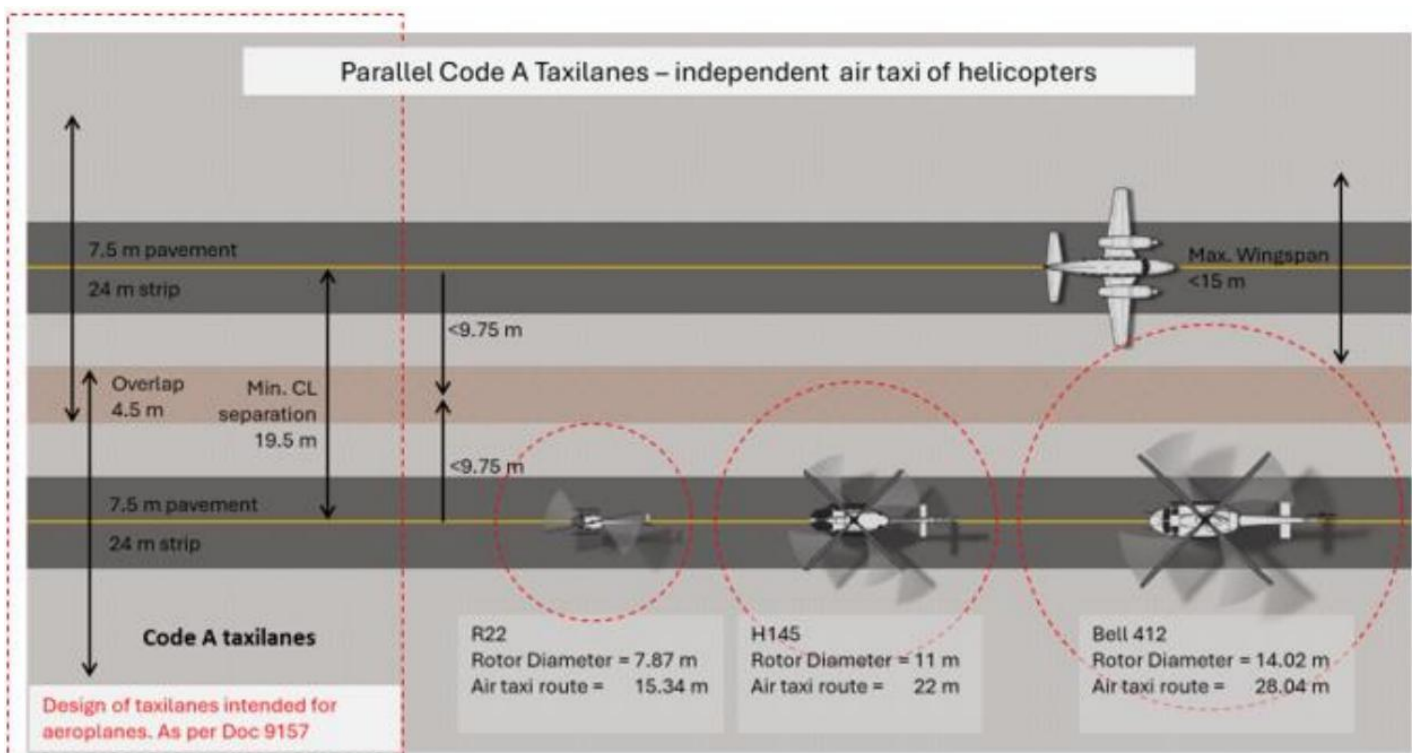
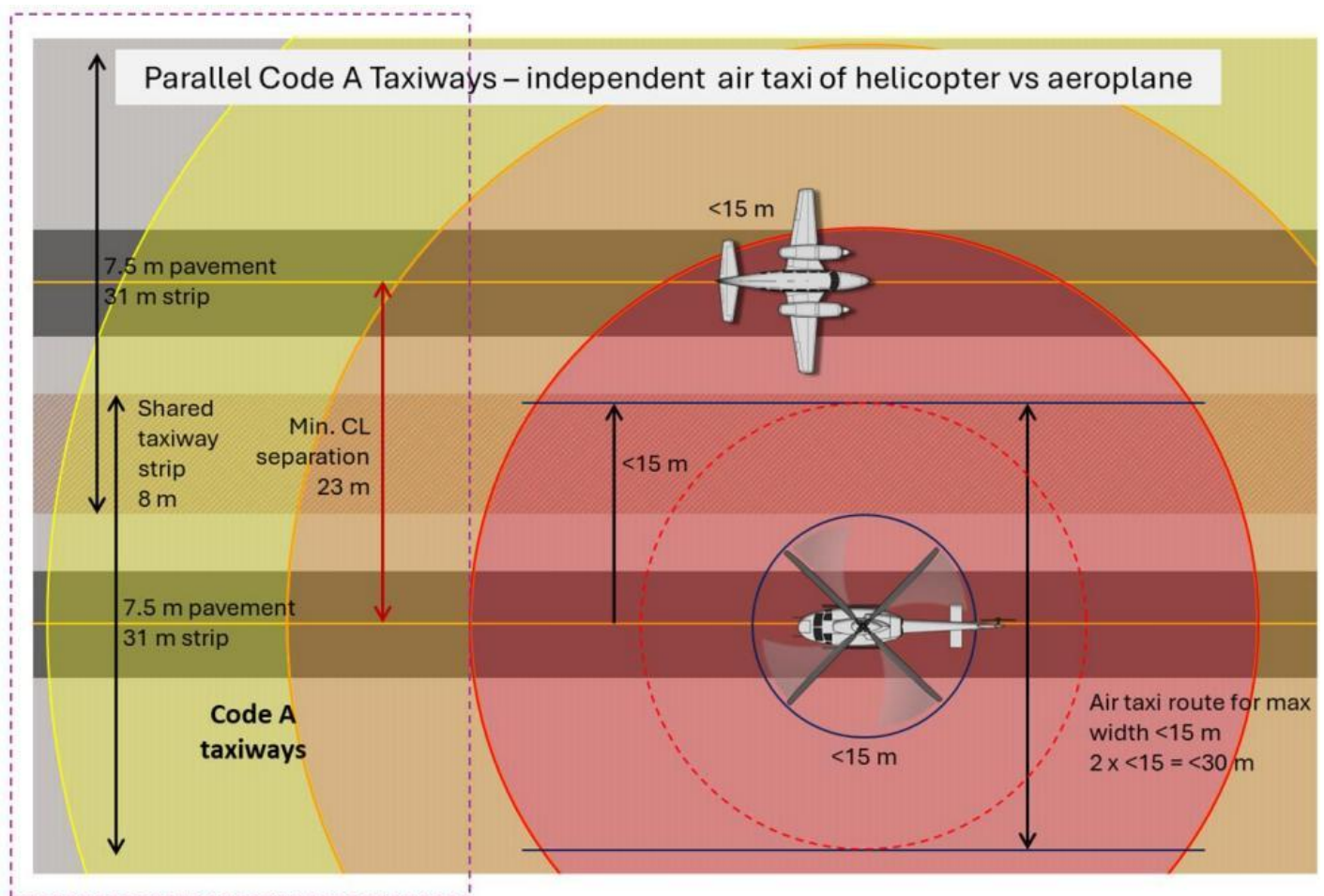

Figure 14: Parallel code A taxilanes and the air-taxi routes for 3 helicopters with a width of less than 15 m (Source: CASA)



Design of taxiways intended for aeroplanes.
As per Doc 9157

Figure 15: Parallel code A taxiways vs the potential peak wind velocities of a Bell 412 (Source: CASA)

Example:

The Bell 412, a popular aeromedical helicopter, has a rotor diameter under 15 m, making it technically suitable for air taxiing on a Code A taxiway. However, at distances beyond the edge of a Code A taxiway strip (15.5 m from the centreline), the helicopter can generate peak wind velocities exceeding 80 km/h. This could affect aircraft holding at an intersecting taxiway or operating on a parallel taxiway. Illustrated in Figure 15.

3.6.4 Air transit routes

3.6.4.1 Air transit routes are a nominated path that a vertical flight aircraft follows that allows for an aircraft to fly at a height not above 100 ft and at a speed greater than 20k kts. Due to the higher speeds and altitude the DW/OW are more dissipated than they would be for the same aircraft air-taxiing but do create the potential for helicopter wake turbulence effects.

3.6.4.2 Where an aerodrome is limited to having vertical flight aircraft parking positions located away from FATO (or FATOs), and where an air-taxi route would introduce an unacceptable DW/OW hazards and risks, then air transit routes may be considered.

3.6.4.3 Downwash may extend to up to 10 rotor diameters below a helicopter when air transiting at speed less than 20 kts, and an equivalent distance for VCA aircraft. Downwash may be vertical below the helicopter or moved by wind. DW/OW should be considered by the aerodrome operator when determining preferred air transit routes above the aerodrome.

The potential for helicopter wake turbulence exists when a helicopter air transits at speeds greater than 15-20 kts. See chapter 2.3 of this AC for the note on Caution: Wake turbulence.

Guidelines for vertical flight aircraft facilities at aerodromes designed for aeroplanes

3.6.4.4 Air transit route should have the following attributes:

- airspace free of obstacles
- not be above aircraft parking areas or where aircraft may be manoeuvring
- not be above areas where people may be impacted by DW/OW
- a corresponding area of ground below for suitable emergency (autorotative or one engine inoperative) landings
- a width that would permit unhindered transit whilst allowing suitable space for errors in manoeuvring.
- minimal variation in direction
- air transit route/s should be described in aerodrome published information.



Figure 16: Bell Jet Ranger airborne over aerodrome taxiway markings (CASA)

3.7 Aprons for vertical flight aircraft

3.7.1 Apron design

3.7.1.1 The hazardous effects of DW/OW from a vertical flight aircraft, and integrated operations between vertical flight aircraft and aeroplanes on the same apron should be carefully assessed.

3.7.1.2 Aprons to be used exclusively by helicopters are divided into 2 design types based on their intended operations: Those designed for accommodating air-taxi (or powered turn-out) parking, and those designed for ground taxi parking. These 2 stand types are D-value-based stands.

3.7.1.3 As well as the D-value-based stands, VCA aprons may also include geometry-based stands designed for (ground) taxi or tow-in and push back of VCA aircraft.

3.7.1.4 All D-value-based stands should have the following features:

- touch down positioning marking (as parking position marking)
- a stand perimeter
- a protection area.

3.7.1.5 Geometry-based stands should have the following features:

- touch down parking position marking (as parking position marking)
- a protection area.

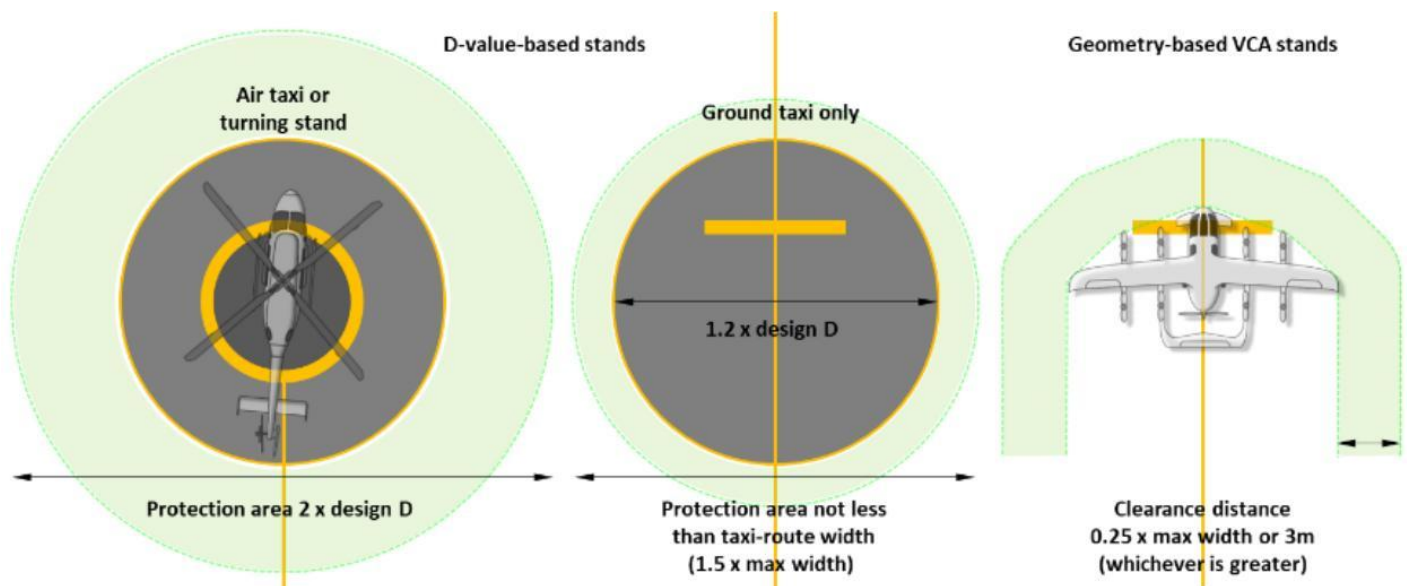

Figure 17: The basic stand geometry for the 3 types of stands (left to right) air-taxi or turning stand, a ground taxi (non-turning) stand and a VCA geometry-based stand (Source: CASA)

3.7.2 D-Value-based aprons

General

3.7.2.1 D-value based stands use the design D for the aircraft(s) intended for that apron or stand (this may be a smaller design vertical flight aircraft than the design vertical flight aircraft for the overall aerodrome).

3.7.2.2 D-value stands should have a stand diameter of $1.2 \times \text{design } D$, surrounded by a stand protection area defined by the operational use of the stand.

3.7.2.3 The stand should have a touchdown positioning marking (TDPM) to correctly align for touchdown or parking.

Protection areas

3.7.2.4 A D-value based stand should be surrounded by a stand protection area which provides obstacle clearance protection for aircraft arriving and departing the stand.

3.7.2.5 For helicopters conducting air transport operations the recommended overall dimension of the stand protection area is 2 x design D whether the vertical flight aircraft is air or ground taxiing.¹⁰

3.7.2.6 Stand protection areas may be overlapped where arrival and departures to stands are not simultaneous. The stand protection area should not overlap the actual stand perimeter of the adjacent stand.

3.7.2.7 For simultaneous arrival and departure operations, the protection areas should not overlap.

¹⁰ This recommendation aligns with guidance from other NAAs for transport category heliports. Refer FAA AC 150/5390 as published from time to time.

Guidelines for vertical flight aircraft facilities at aerodromes designed for aeroplanes

Touch down positioning markings (TDPM)

Touch down positioning marking - circle (TDPC)

3.7.2.8 A TDPC should be used wherever a helicopter or VCA is permitted to align their heading as required before touching down and may be used within:

- a. a FATO with a TLOF
- b. a TLOF located at the end of an air-taxi or air-transit route

or

- c. a vertical flight aircraft stand.

3.7.2.9 A TDPC should be used any time a powered turn, either on the ground or after a lift-off, is needed to exit the stand.

Touch down positioning marking - shoulder line (TDPS)

3.7.2.10 The TDPS is similar in use to a pilot stop line marking used on a fixed wing parking position.

3.7.2.11 A single direction TDPS should be used whenever a vertical flight aircraft needs to be aligned in one direction only.

3.7.2.12 When a single direction TDPS is used on a stand the aircraft can be pushed back from the stand or can taxi through following a continued alignment line.

3.7.2.13 For stands accommodating arrivals and departures from opposite directions 2 TDPS should be used.

3.7.3 Apron design types

Mixed use aprons and parking stands

3.7.3.1 Although apron markings are not required for aircraft 5,700 kg or less, where mixed use aprons and parking stands are intended unique attributes of vertical flight aircraft should be considered and markings provided where deemed appropriate.

3.7.3.2 Where an apron is intended for simultaneous mixed operations, and where the same parking position can be used by all form of aircraft the aerodrome operator should determine the most demanding design feature of each aircraft.

3.7.3.3 The most demanding feature may not always be the physical characteristics of the aircraft but may include hazards produced by the aircraft such as jet blast, prop wash or DW/OW. Turning radius, lead in lead out hazards from or to adjacent parking positions and aircraft servicing requirements may also be influencing factors.

Guidelines for vertical flight aircraft facilities at aerodromes designed for aeroplanes

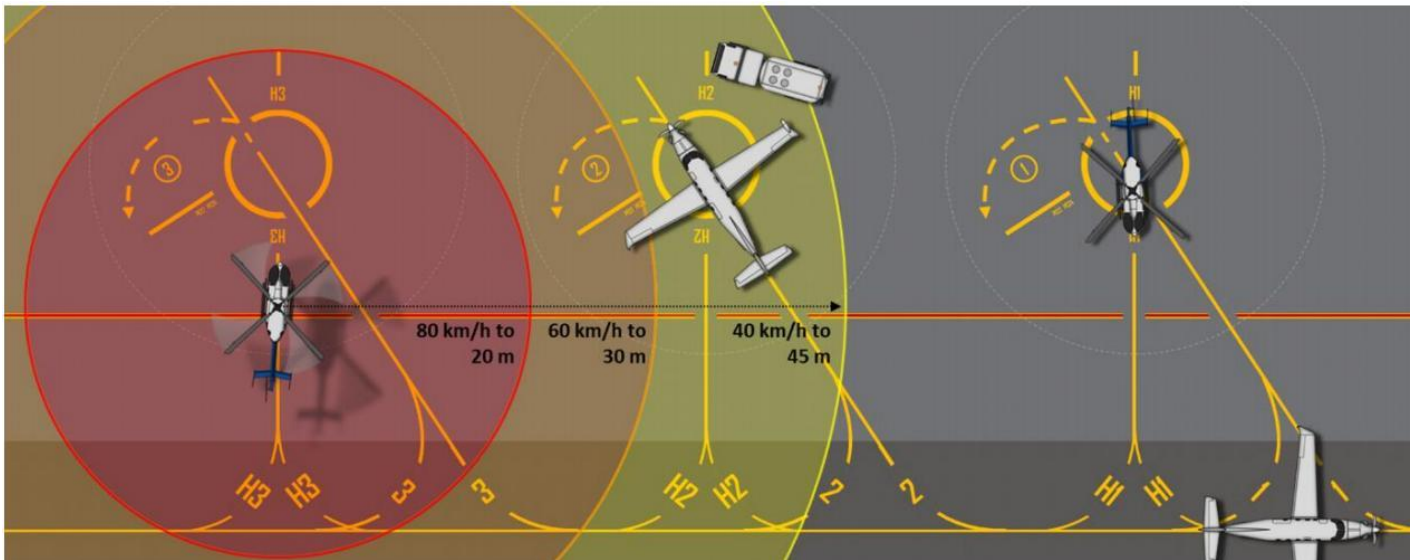

Figure 18: Mixed use apron design (source: CASA)

3.7.3.4 Figure 18 show a fictional mixed-use apron. Contributing stand spacing factors include the turn radius for the fixed-wing aeroplane and ensuring the adjacent stand is affected by potential peak winds less than 60 km/h. The primary parking position markings (for the fixed-wing aircraft in this case) take precedent over the vertical flight aircraft markings. 2 x design D protection area shown for illustration purposes.

Ground taxi aprons

3.7.3.5 Notwithstanding paragraph 3.7.2.5 of this AC, where an apron caters for ground taxiing operations that do not require a vertical flight aircraft to turn for alignment or to depart, then the protection area surrounding the stand may be 1.5 x design D in diameter. This is likely to be associated with a TDPS.

3.7.3.6 Where the vertical flight aircraft needs to turn to taxi out of the stand or to align with the wind while taxiing into the stand, then a larger protection area is required. A ground taxi stand, accommodating a turn should have a protection area of 2 x design D. This is likely to be associated with a TDPC.

Code B apron taxilane

Ground-taxi apron

Code B apron taxilane

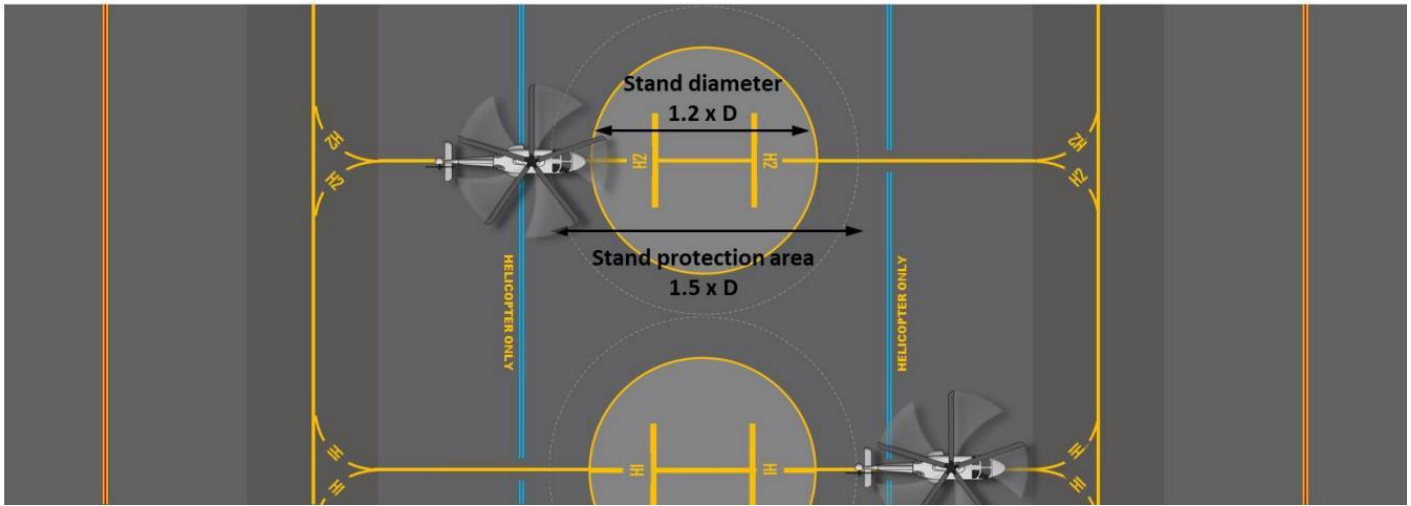

Figure 19: Simultaneous ground taxi apron (source: CASA)

3.7.3.7 Figure 19 shows an example of a helicopter apron that only permits ground taxiing to the stands. These 2 stands are spaced for simultaneous operations with the stand protection areas not overlapping. The stands are marked with dual direction TDPS. The stand protection areas are shown for illustration purposes.

Guidelines for vertical flight aircraft facilities at aerodromes designed for aeroplanes

Air taxi aprons

3.7.3.8 Where an apron caters specifically for air taxiing operations then the required protection area surrounding the stand should be $2 \times D$ in diameter.

3.7.3.9 As with ground taxiing stands, the protection areas may only overlay if operations are nonsimultaneous to adjacent stands.

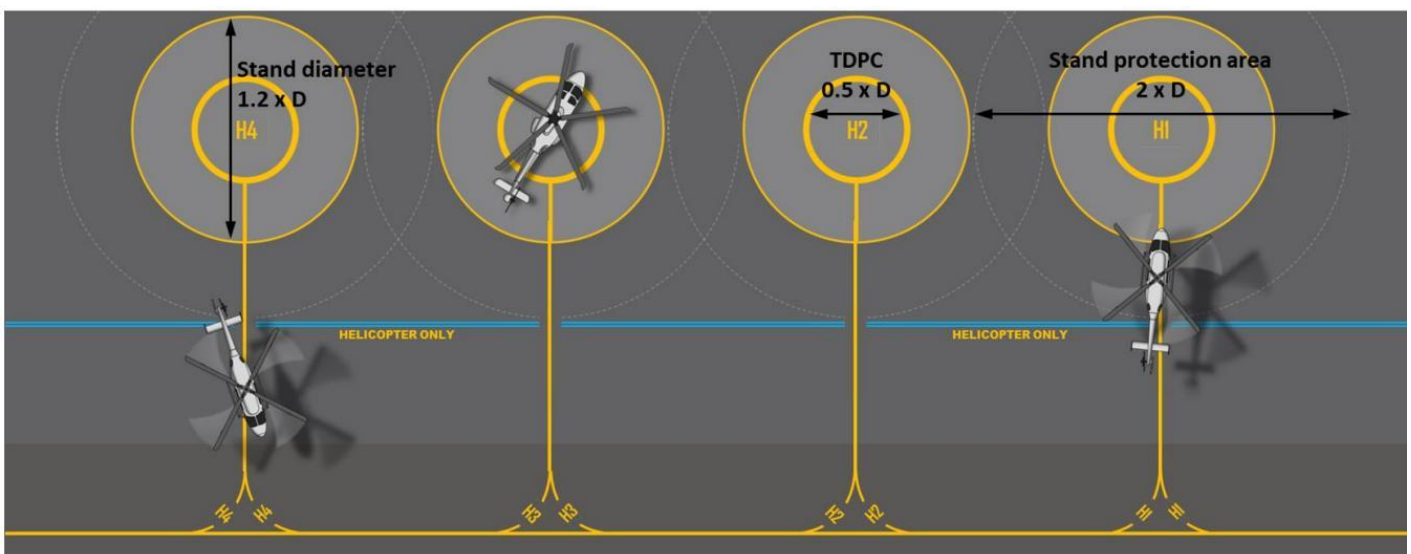

Figure 20: Non-simultaneous air-taxi apron (source: CASA)

3.7.3.10 Figure 20 shows an example of air-taxi stand spacing where the protection areas are overlapped for non-simultaneous operations.

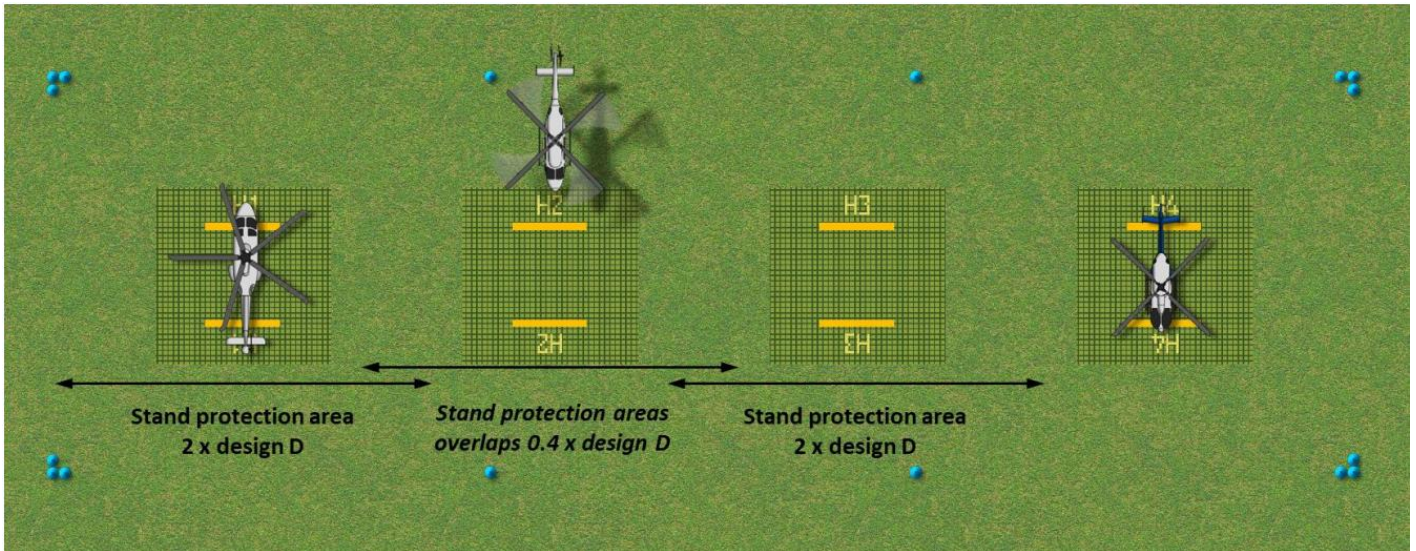

Figure 21: Non-simultaneous air-taxi (natural surface) apron (source: CASA)

3.7.3.11 Figure 21 shows an example of an air taxi apron with a natural surface with dual direction TDPS and stand numbering and intended for non-simultaneous arrival and departures. The illustration suggests grass stands with a ground reinforcing product.

TLOF on apron

3.7.3.12 Where a vertical flight aircraft is intended to touch down or lift off on an apron the TLOF should be surrounded by a stand protection area with a diameter of 2 x Design D.

3.7.3.13 The TLOF should be distinguishable from the parking areas of the apron using a parking clearance line.

Guidelines for vertical flight aircraft facilities at aerodromes designed for aeroplanes

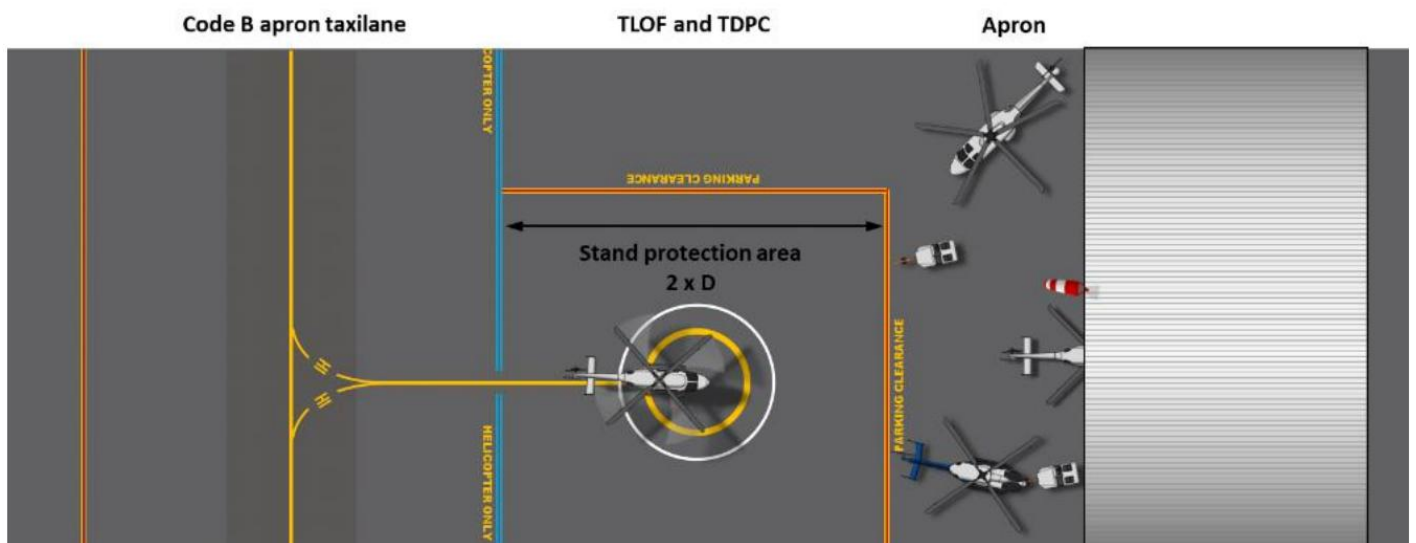

Figure 22: TLOF on an apron (source: CASA)

3.7.3.14 Figure 22 shows an example of how a TLOF might be designed. With TLOF and TDPC markings and the stand protection area surrounded by parking clearance lines (the stand protection area need not be square).

Narrow apron options

3.7.3.15 In circumstances where a stand or TLOF and its associated protection area cannot be accommodated within the boundary of the parking area, the following provides alternatives to facilitate air taxiing vertical flight aircraft.

3.7.3.16 Despite the recommendations in this section, an aerodrome operator should conduct a safety assessment as part of the design process for any vertical flight facility (in this case aprons and apron taxilanes being used by vertical flight aircraft operators). The recommendations are based on taxi-route guidance and vertical flight aircraft stand dimensions and do not fully consider the hazard and associated risks of DW/OW in a confined apron scenario, and these hazards will change depending on the aircraft types in use and their operation, and the risk to other aircraft operations, people and equipment.

3.7.3.17 Where possible vertical flight aprons should be associated with an adjacent taxilane of not less than code B width. A Code B taxilane will provide an air-taxi route for vertical flight aircraft with a maximum overall width of up to 16.5 m¹¹.

Note: Vertical flight aircraft with a maximum width of greater than 16.5 m will require more demanding taxilanes.

Guidelines for vertical flight aircraft facilities at aerodromes designed for aeroplanes

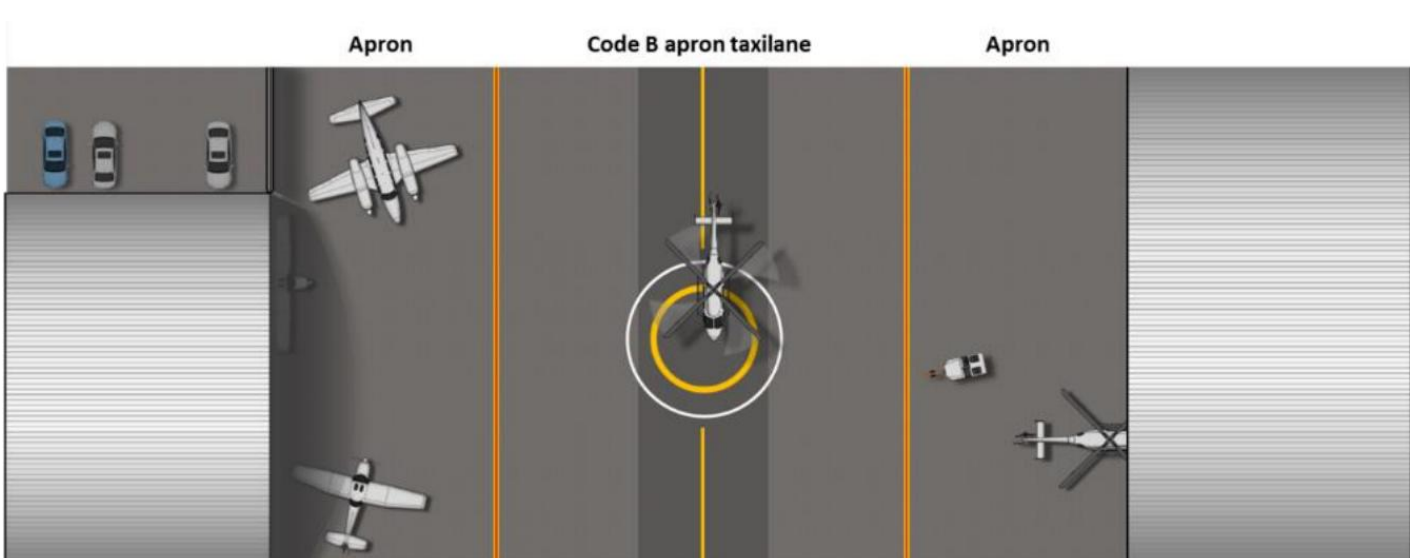

Figure 23: TLOF on a Code B taxilane (source: CASA)

3.7.3.18 Figure 23 shows an example of a TLOF and TDPC located on a Code B taxilane, where the destination parking area is too narrow to allow for an aircraft to safely touch down.

3.7.3.19 Where vertical flight aircraft are air-taxiing or air-transiting to a narrow parking position and a Code B taxilane or larger is adjacent, the TLOF with a TDPM should be provided centred on the taxilane.

3.7.3.20 Where a Code A taxilane is provided, then air transit or air-taxi operations should be restricted to vertical flight aircraft with a maximum overall width less than 12 m.¹²

3.7.3.21 Where vertical flight aircraft are air-taxiing or air-transiting to the vicinity of a narrow parking position and a Code A taxilane is adjacent, a TLOF with a TDPM should be provided:

- a. Centred such that the stand protection area is clear of any apron not associated with the vertical flight aircraft operation.
- b. Where the stand protection area extends beyond the edge of the taxilane, an equipment clearance line should be marked to ensure the TLOF is free of obstacles during lift-off and touch down operations.

Refer to chapter 8 of the Part 139 MOS for equipment clearance line specifications.

Note: Other aerodrome users should be considered by the aerodrome operator when intending to locate a TLOF on a taxiway or taxilane. Vertical flight aircraft operators will need to consider delays to other aerodrome users when their aircraft is using the TLOF.

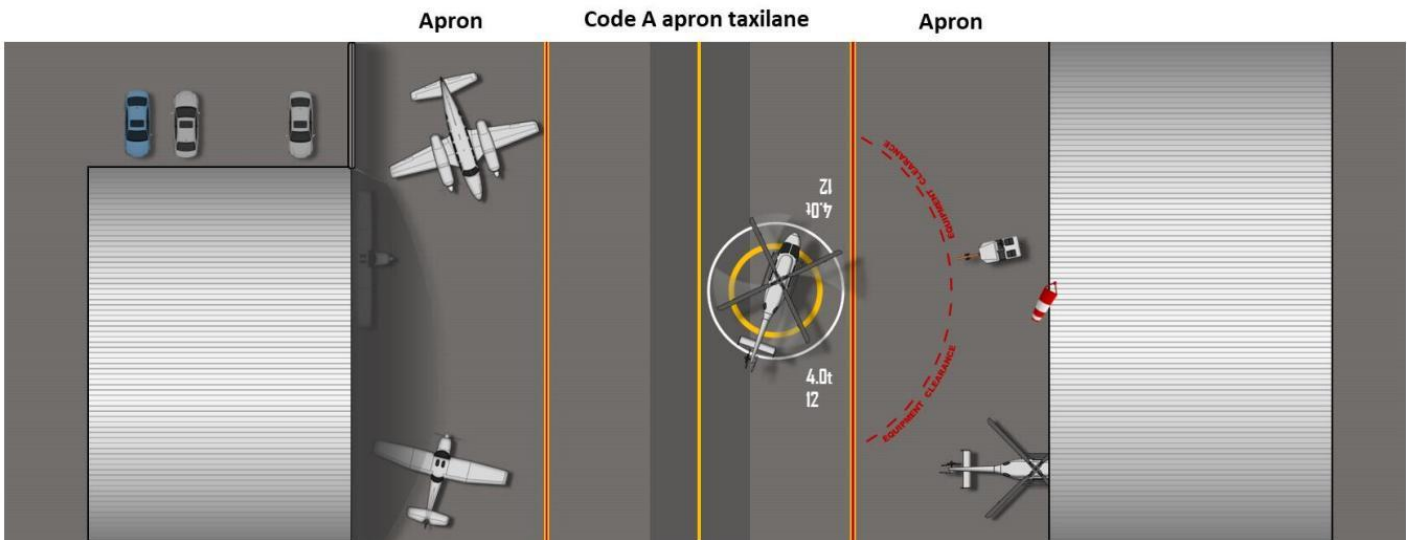

Figure 24: TLOF for a narrow parking area (source: CASA)

3.7.3.22 Figure 24 shows a narrow parking area example on a code A apron taxilane. The protection area outlined with the use of an equipment clearance line.

3.7.4 Geometry-based aprons

3.7.4.1 Geometry based stands were introduced in AC 139-V.01 to accommodate VCA operations where the aircraft will ground taxi or be towed to a stand. Figure 25 shows an example of a geometry based apron.

3.7.4.2 Geometry based stands may be used for aprons designed for VCAs that will be ground taxied into the parking position, then pushed back for departure.

Further details of the geometry-based stands are included in AC 139.V-01.

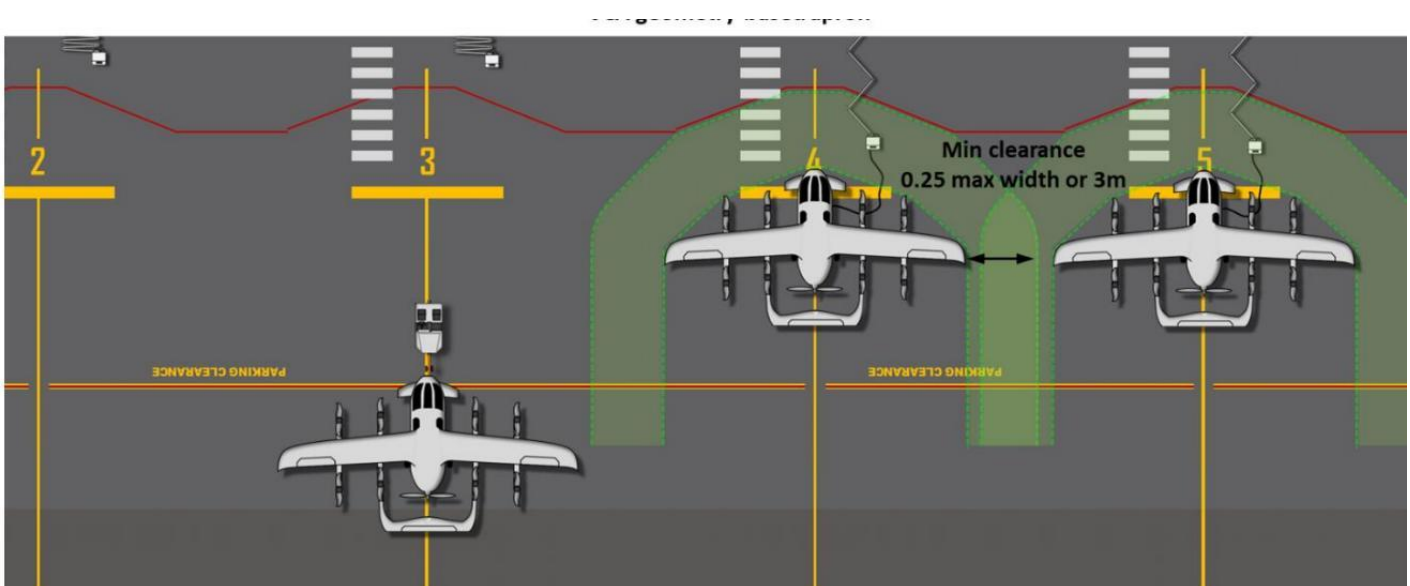

Figure 25: Geometry-based apron (Source: CASA)

4 Obstacle limitation surfaces

Existing aerodromes will already have obstacle limitation surfaces (OLS) established. However, protection surfaces for on aerodrome helicopter facilities have been very rarely included as part of an aerodromes OLS.

4.1 Aeronautical assessments

4.1.1 An assessment of intended activities at an airport, the introduction of new aviation infrastructure in the vicinity of an aerodrome, or the introduction of more demanding aircraft may trigger the need for an aeronautical study to determine whether hazards and risks to the aerodrome, or those aircraft intending to use the aerodrome, remain acceptable to the aerodrome operator and those using the facility.

Chapter 4 of AC 139.R-01 provides details on the process of an aeronautical assessment for heliports.

This process can be equally applied to vertical flight aircraft facilities at an aerodrome.

4.2 OLS general specifications

4.2.1 Where the aerodrome has nominated the runway as the FATO for vertical flight aircraft operations then no additional OLS is required for vertical flight aircraft operations.

4.2.2 All other FATOs should have at least the following protection surfaces prepared:

- a. the FATO protection area
- b. take-off climb and approach surface/s.

4.2.3 Transitional surfaces or side slopes are included (when required).

4.2.4 Aerodrome operator should ensure that no permanent or transient objects penetrate the surfaces during flight operations to and from the FATO.

4.2.5 FATO protection area

4.2.5.1 A FATO should be surrounded by an area that is free from obstacles. The FATO protection area (or safety area) is intended to reduce the risk to an aircraft should it diverge from the centre of the FATO.

For a FATO planned for helicopter operations, the safety area should be designed as per the specifications outlined in section 3.1 of AC 139.R-01.

Where no helicopter operations are planned, the protection area should be designed as per the specifications in section 4.2 of AC 139.V-01.

4.2.6 Take-off climb and approach surface

4.2.6.1 Aerodrome operators may design their take-off climb and approach surface as per the guidance in chapter 4 of AC 139.R-01, or they may use the take-off/approach slope design guidance in chapter 4 of AC 139.V-01.

4.2.6.2 A slope of 8% is recommended for the take-off climb and approach surfaces for a FATO at an aerodrome. This slope will allow for helicopters operating performance classes (PC) 2 and 3.

4.2.6.3 Where an aerodrome intends to accommodate helicopters operating performance class 1 (PC 1):

- a. The aerodrome operator may publish information that PC1 operations be restricted to arriving and departing from a runway.
- b. Where (a) is not preferred and the aircraft operator needs to perform PC1 operations, the take-off climb and approach surfaces should be designed with a 4.5% slope.

4.2.6.4 Where an aerodrome plans to accommodate VCA but not helicopters then the slope for the take-off climb surface slope or combination of slopes and section lengths should be determined with reference to the obstacle environment and intended aircraft performance capabilities.

Refer to chapter 4 of AC 139.R-01 or AC 139.V-01 for specifications on take-off climb and approach surfaces.

Performance Class 1 (PC1) operations

For many existing aerodromes, a take-off climb and approach surface with slope of 4.5% for a standalone FATO, may impose unintended operational restrictions on the airfield (such as needing to hold aircraft some distance from the FATO to ensure the FATO OLS is not infringed).

Aerodrome operators have the option that where the approach or take-off climb surfaces, to a standalone FATO, cannot be provided for PC1 operations, then approach and take-off climb, for PC1 operations, should be limited to a runway.

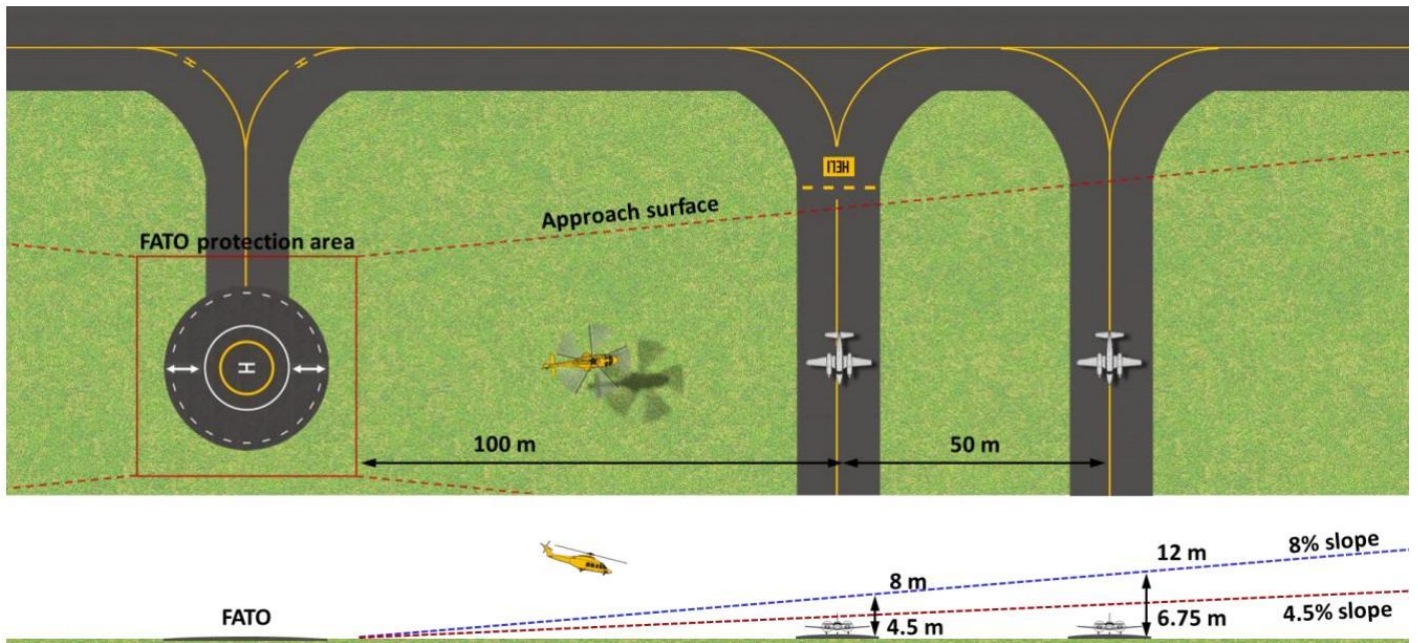

Figure 26: FATO approach and departure slope options (Source: CASA)

4.2.6.5 Figure 26 shows a visualisation of the 4.5% vs the 8% approach/departure slopes and possible infringements of the slope with taxiways located at particular distances from the FATO.

4.2.7 Transitional surface

4.2.7.1 In AC 139.R the transitional surface is only specified for heliports that support a point-in-space (PinS) approach procedure utilizing a visual segment surface. However, an aerodrome operator

DRAFT

Guidelines for vertical flight aircraft facilities at aerodromes designed for aeroplanes

may choose to include the transitional surfaces where a safety assessment determines that additional lateral protection may be required.

Aerodrome operators may design their FATO transitional surfaces as per the guidance in Chapter 4 of AC 139.R-01 chapter 4, or they may use the simplified transitional surface design guidance in Chapter 4 of AC 139.V-01.

4.2.8 Stand protection area

4.2.8.1 The stand protection area should also be thought of as part of the obstacle protection surfaces. Details of the stand protection area specifications are covered in chapter 3.7 of this AC.

Visual aids

5.1 General

5.1.1 All specifications for the markings described in this chapter can be found in:

Chapter 5 Visual Aids of either AC 139.R-01 or AC 139.V-01.

5.1.2 Markers and markings should be clearly visible to the facility user by way of:

- a. provision of a contrasting background marking (a box or border)
- b. where allowed for in the specifications below, the selection of an appropriate contrasting colour
- c. any other method that would increase the conspicuity of the marking or marker in operational conditions.

5.1.3 The night-time visibility of markers and markings may be supplemented by reflective/refractive material providing that such material does not pose a hazard if dislodged.

5.2 Options for marking the FATO

5.2.1 Where an aerodrome has a FATO or FATOs for their vertical flight aircraft operations then the FATO/s should be marked.

5.2.2 However, where a FATO is clearly self-evident against its respective background, such as a paved FATO on a grassed area, then the FATO perimeter marking is not required. In all other cases a perimeter marking should be provided.

5.2.3 Markings that may be used within a FATO, depending on its intended operations, include:

- FATO perimeter marking
- TLOF perimeter marking
- touchdown positioning markings (shoulder line or circle)
- aiming point marking
- heliport identification marking
- flight path alignment guidance line.

5.2.4 The marked shape of the FATO is optional, so, long as it meets the required size specifications.

Note: Based on research¹³ conducted by the FAA, a square FATO is the preferred visual cue for judging the rate of closure, altitude, attitude and angle of approach.

¹³ See the National EMS Pilots Association (NEMSPA) survey, 2011.

5.2.5 Standalone FATO with an aiming point

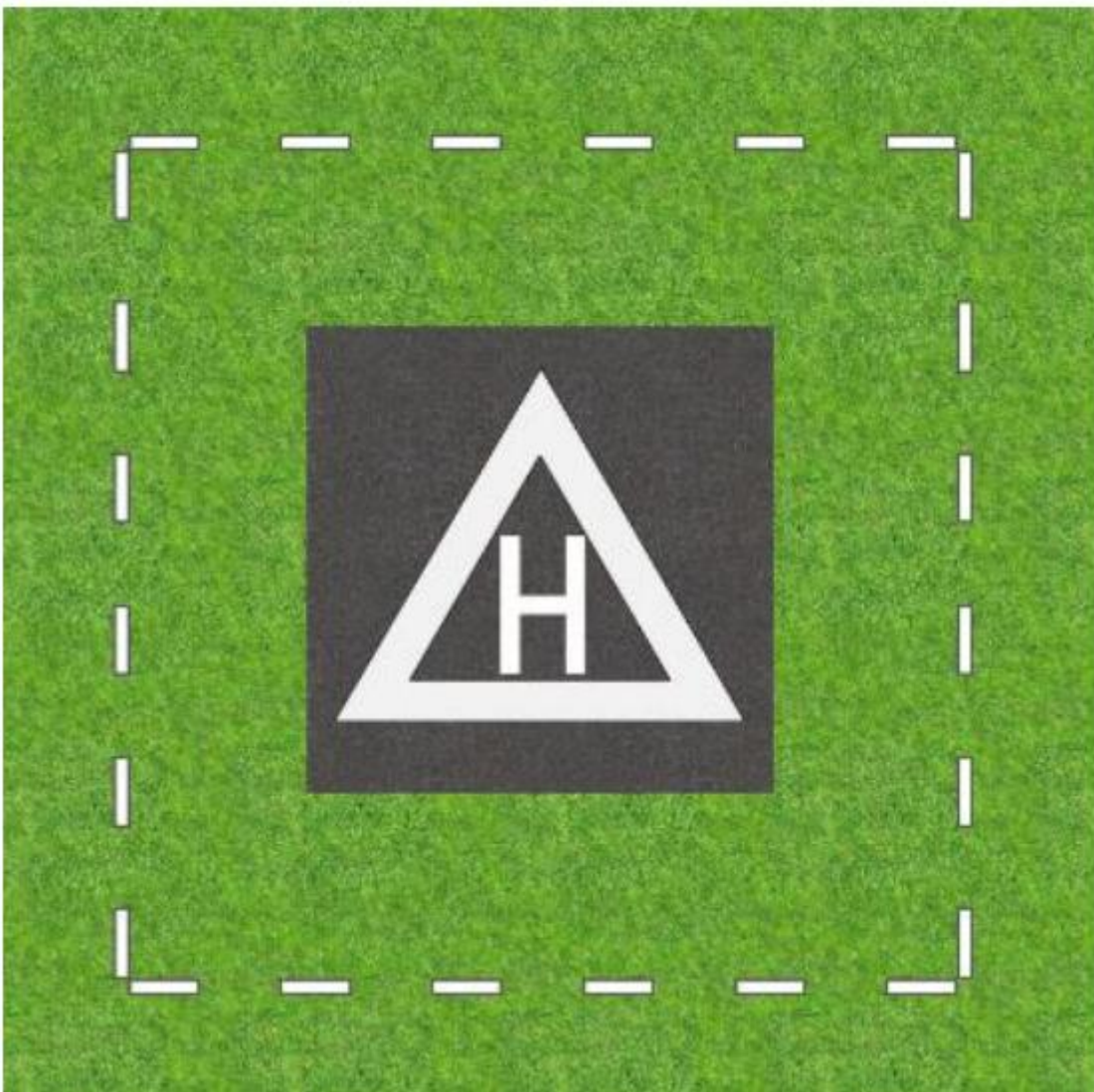

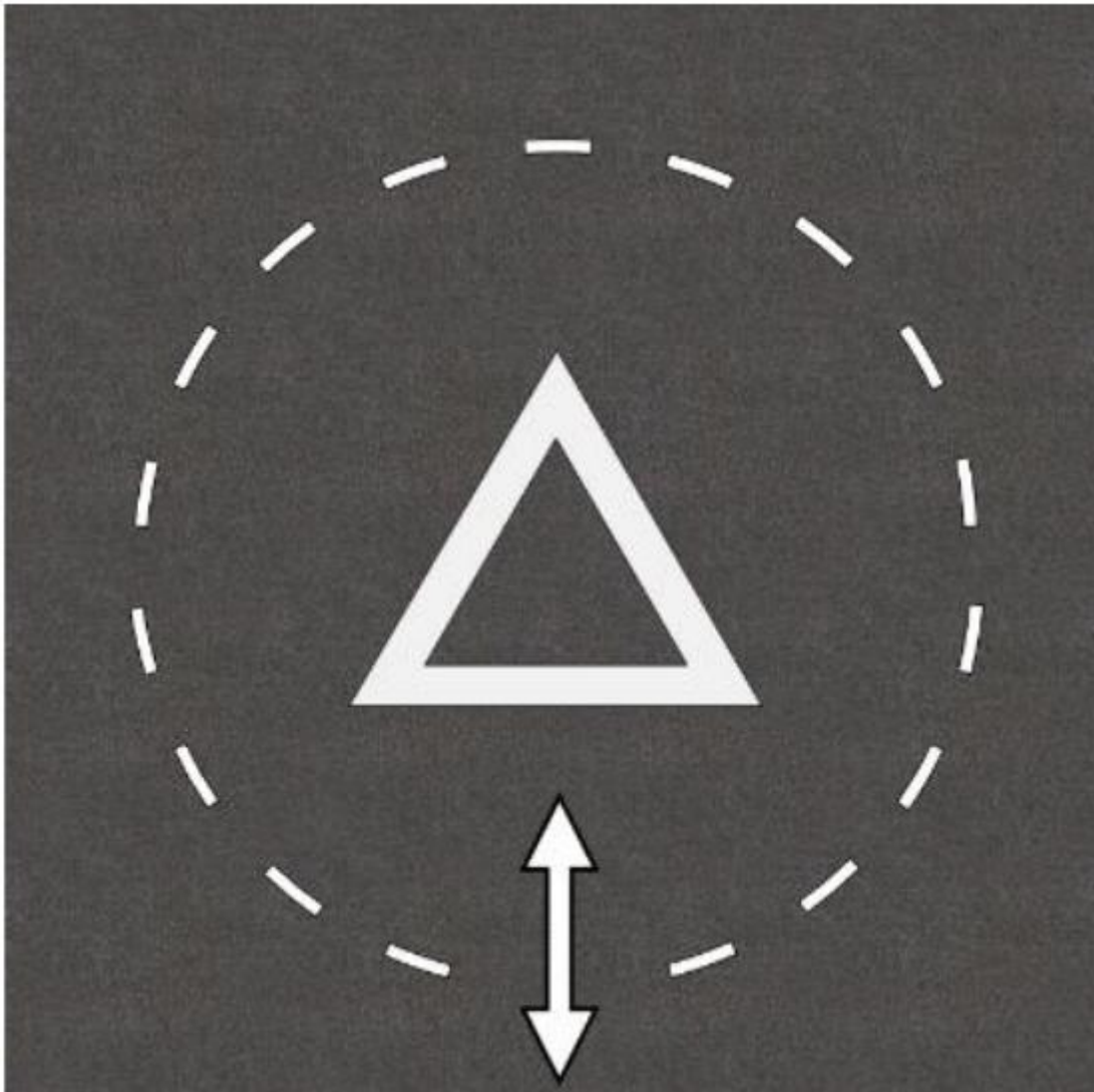

Figure 27: Aiming point FATOs

5.2.5.1 Figure 27 provides 2 examples of FATOs marked with FATO perimeter and aiming point markings. Optional heliport identification marking (left) and a flight path alignment guidance marking (right) are shown.

5.2.5.2 Where a FATO is provided for a vertical flight aircraft to arrive and depart but NOT touch down then the FATO should be marked with:

- a dashed white FATO perimeter marking (or markers)
- a white aiming point marking (triangle)

optionally:

- a heliport identification marking
- flight path alignment guidance markings

- D-value markings.

5.2.6 Standalone FATO with a TLOF

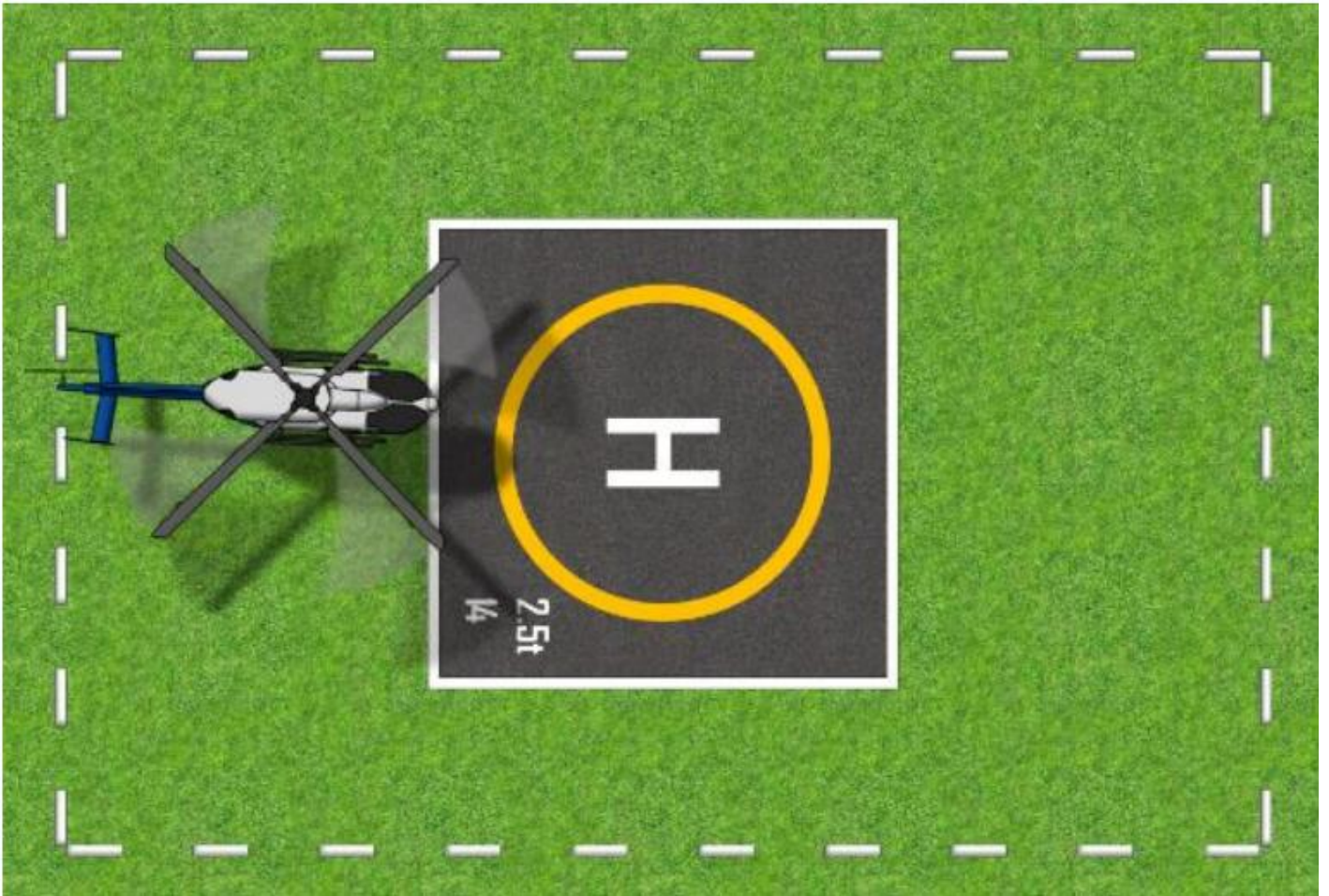
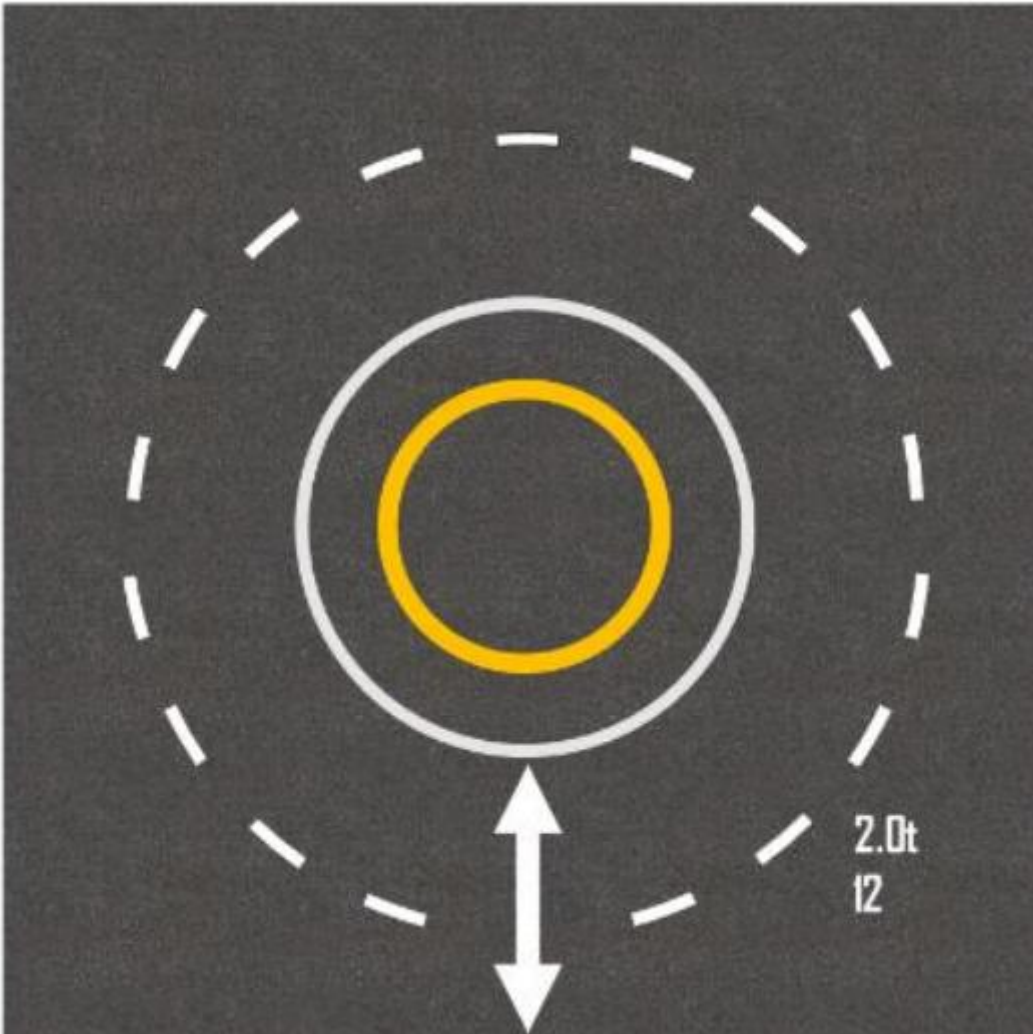

Figure 28: FATO with a TLOF



5.2.6.1 Figure 28 provides 2 examples of FATOs marked with FATO perimeter, TLOF perimeter and TDPC markings. Optional markings shown are a heliport identification marking (left) and a flight path alignment guidance marking, plus a maximum mass and a D-value marking (right).

5.2.6.2 Where a FATO is provided for a helicopter/VCA to arrive and to touchdown then alignment guidance should be provided. This FATO should be marked with:

- a dashed white FATO perimeter marking
- a solid white TLOF perimeter marking
- a yellow touch down positioning marking; shoulder-line or circle (TDPS or TDPC). optionally:
- a heliport identification marking
- maximum allowable mass and/or D-value markings
- flight path alignment guidance markings.

5.2.7 Runway type FATO

5.2.7.1 An aerodrome operator may choose to provide a runway type FATO for helicopter/VCA operations. A runway type FATO should be marked by:

- 1 m x 9 m white FATO edge markings on pavement
- 1 m x 3 m gables on a natural surface (preferably banded in white and red or white and orange)
- 9 m runway designation markings that include the letter H above the two-digit runway heading numbers

optionally:

- a yellow touchdown positioning alignment marking¹⁴.

5.2.8 Taxiway or taxiway intersection nominated as a FATO

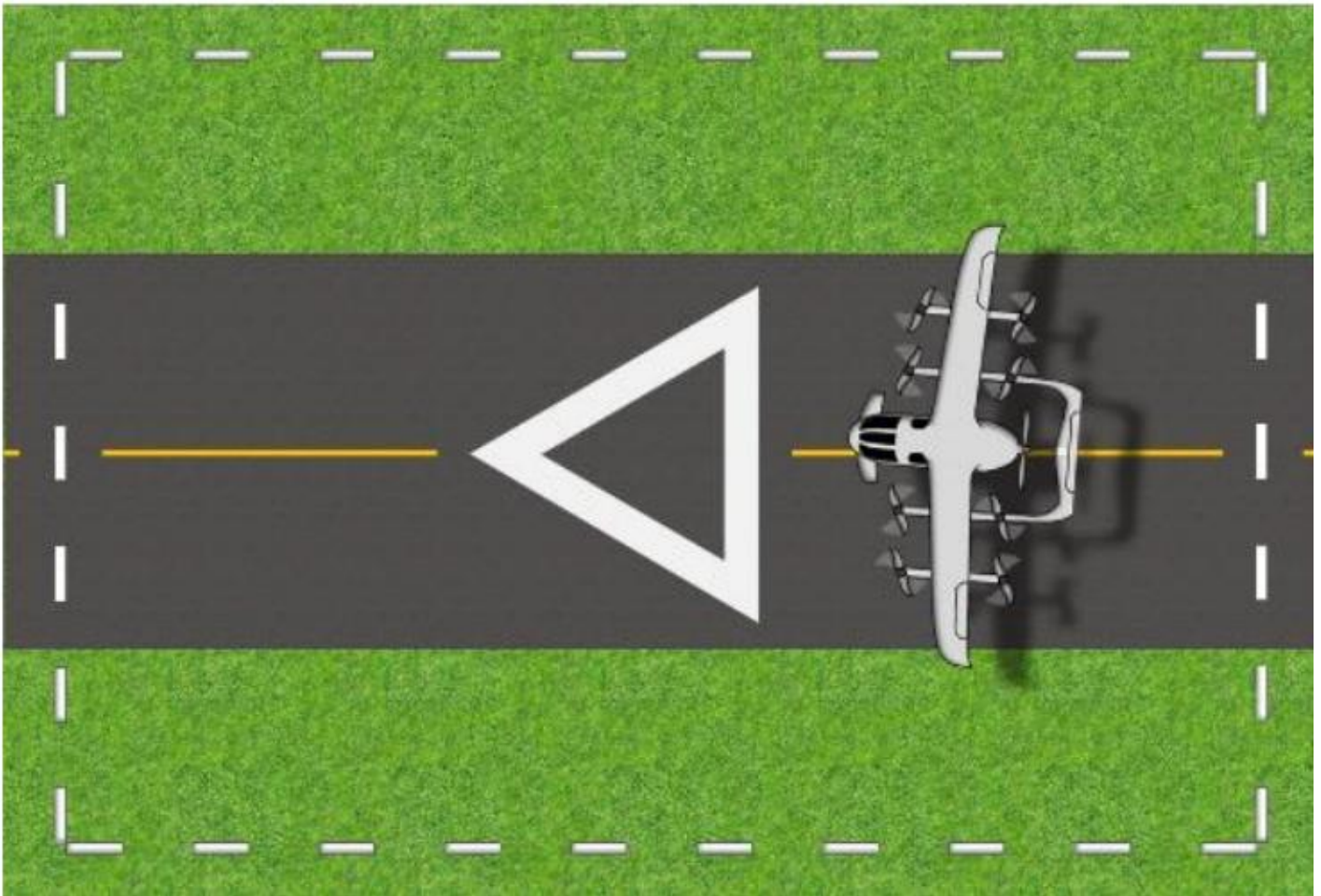
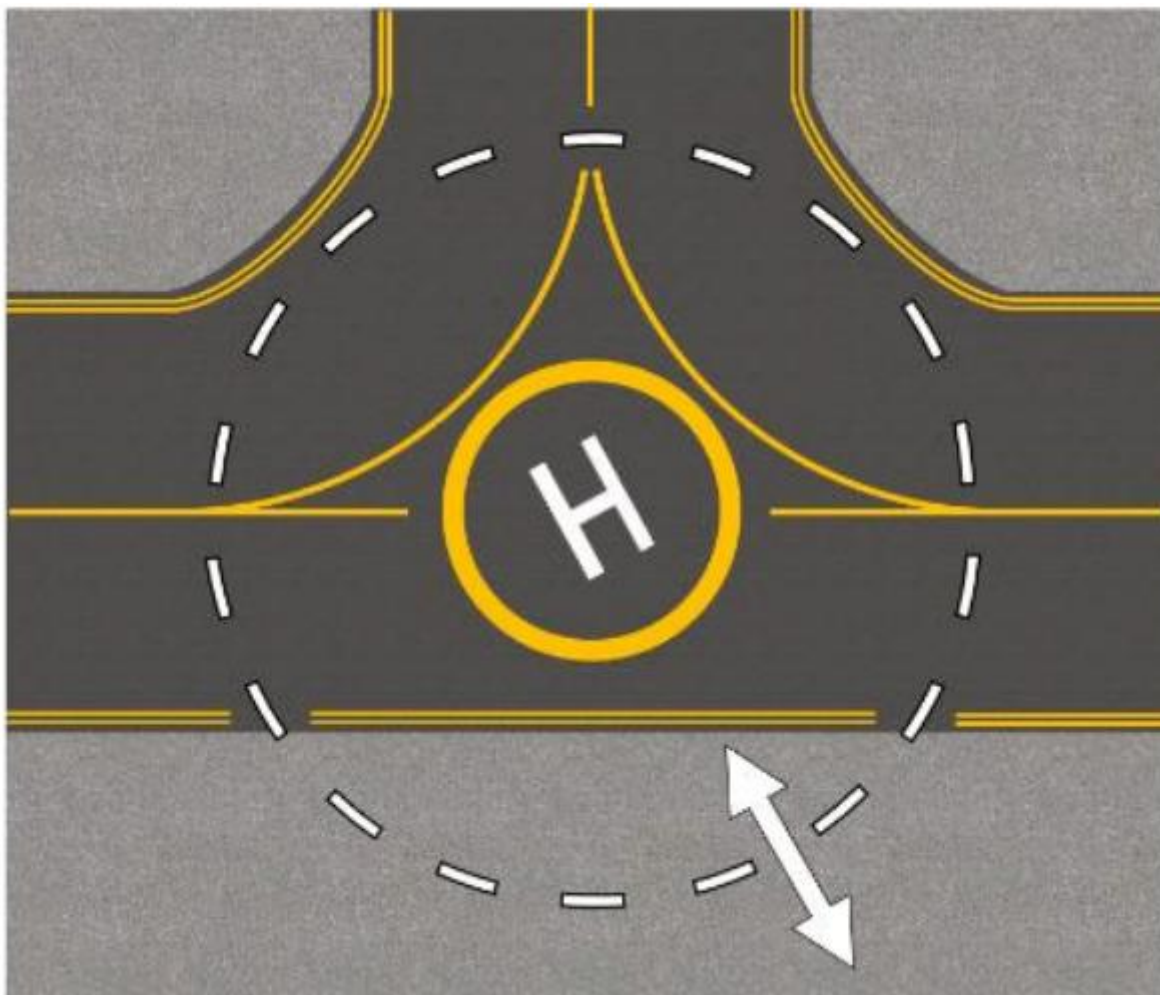

Figure 29: Taxiways with a FATO (source: CASA)



DRAFT

Guidelines for vertical flight aircraft facilities at aerodromes designed for aeroplanes

5.2.8.1 Figure 29 provides 2 examples of taxiway areas nominated as FATOs marked with FATO perimeter markings and an aiming point (left) and a TDPC and flight path alignment guidance marking (right).

5.2.8.2 An aerodrome operator may nominate a section of taxiway or a taxiway intersection as a FATO for vertical flight operations. The area designated as a FATO should be marked by:

- a dashed white FATO perimeter marking (or markers)

optionally:

- a white aiming point marking or yellow touch down positioning marking
- flight path alignment guidance markings
- maximum allowable mass and/or D-value markings

- heliport identification marking.

5.2.8.3 If a taxiway is nominated for vertical flight aircraft to touchdown and the taxiway surface is self-evident or already marked with taxiway edge markings, a white TLOF perimeter marking is not required. However, a yellow TDPM should be marked anytime touchdown is intended.

5.2.9 Additional marking considerations for aerodrome FATOs

Taxiway intersection FATO to holding point

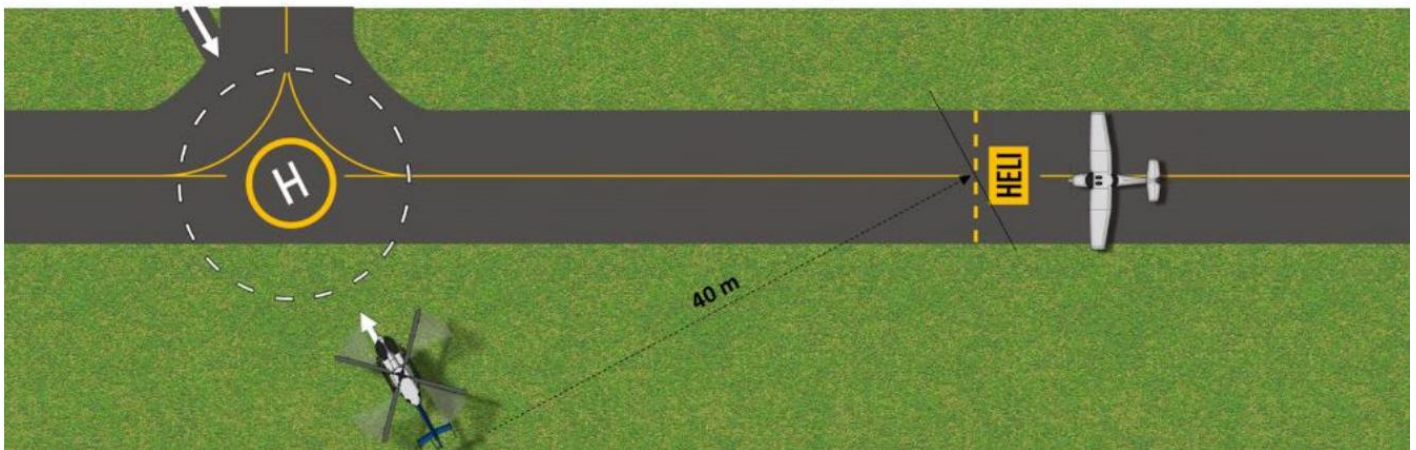

Figure 30: FATO on a taxiway clearance to holding position (source: CASA)

5.2.9.1 Figure 30 shows an example showing an aircraft stopped at a holding position and information marking while a helicopter completes an approach to an aerodrome's FATO.

5.2.9.2 A FATO should be protected from incursions during their use in a similar manner to runways when that runway is in use.

5.2.9.3 Where an approach or take-off climb surface, for a vertical flight aircraft crosses over a taxiway:

Intermediate holding position markings and information markings or movement area guidance signs (MAGS) should be considered to warn aerodrome users of the FATO area and ensure other aircraft can be held short from an operational FATO.

- Intermediate holding positions should be marked not less than 40 m away from the extended approach and departure path to the FATO.

5.2.9.4 Specifications for holding point marking and information markings can be found in Chapter 8 of the Part 139 MOS.

Note: Suggested text for information marking or MAGS should be HELI.

Guidelines for vertical flight aircraft facilities at aerodromes designed for aeroplanes

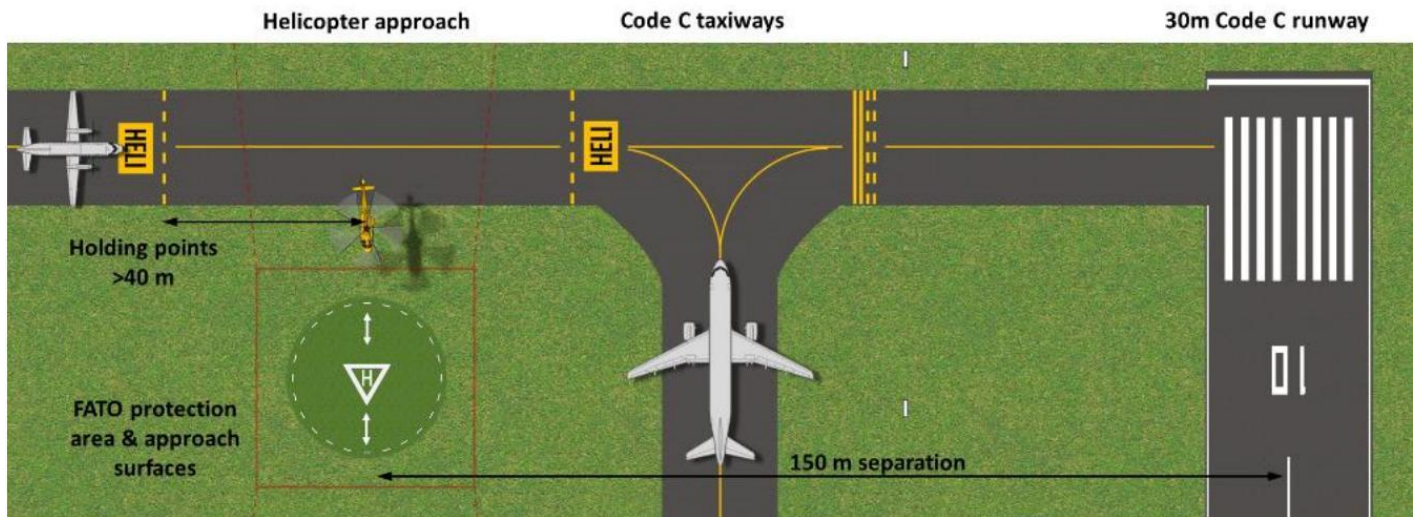

Figure 31: Standalone FATO and separation distances (source: CASA)

5.2.9.5 Figure 31 shows an example of a FATO, with an aiming point, adjacent to a runway, with both being used for parallel simultaneous operations. Holding points are located where the approach crosses the taxiway.

5.3 Touch down positioning marking and circle

5.3.1 A touch down positioning marking shoulder-line (TDPS) and the touch down positioning circle (TDPC) are the markings that a pilot uses to align their vertical flight aircraft within the TLOF or a stand before touching down, or when parking.

Specifications for TDPC and TDPS markings can be found in Chapters 5 of AC 139.R-01 and AC 139.V-01.

Pilot awareness of the purpose of visual aids is increasing. However, not all pilots may be aware of the operational intention denoted by the marking. Visual aids are provided to give pilots guidance, situational awareness and to mitigate hazards.

Controls intended by the markings may not be universally understood. Hence, published information should reflect the intent of the marking.

For instance, as shown in Figure 29: The correct alignment on a TDPC should have the pilots' seat over the yellow TDPC. (Left hand image below)

If a pilot approaches to align their seating position with the correct alignment within the TDPC it reduces the potential risk of a tail rotor strike during the final approach to the TLOF.

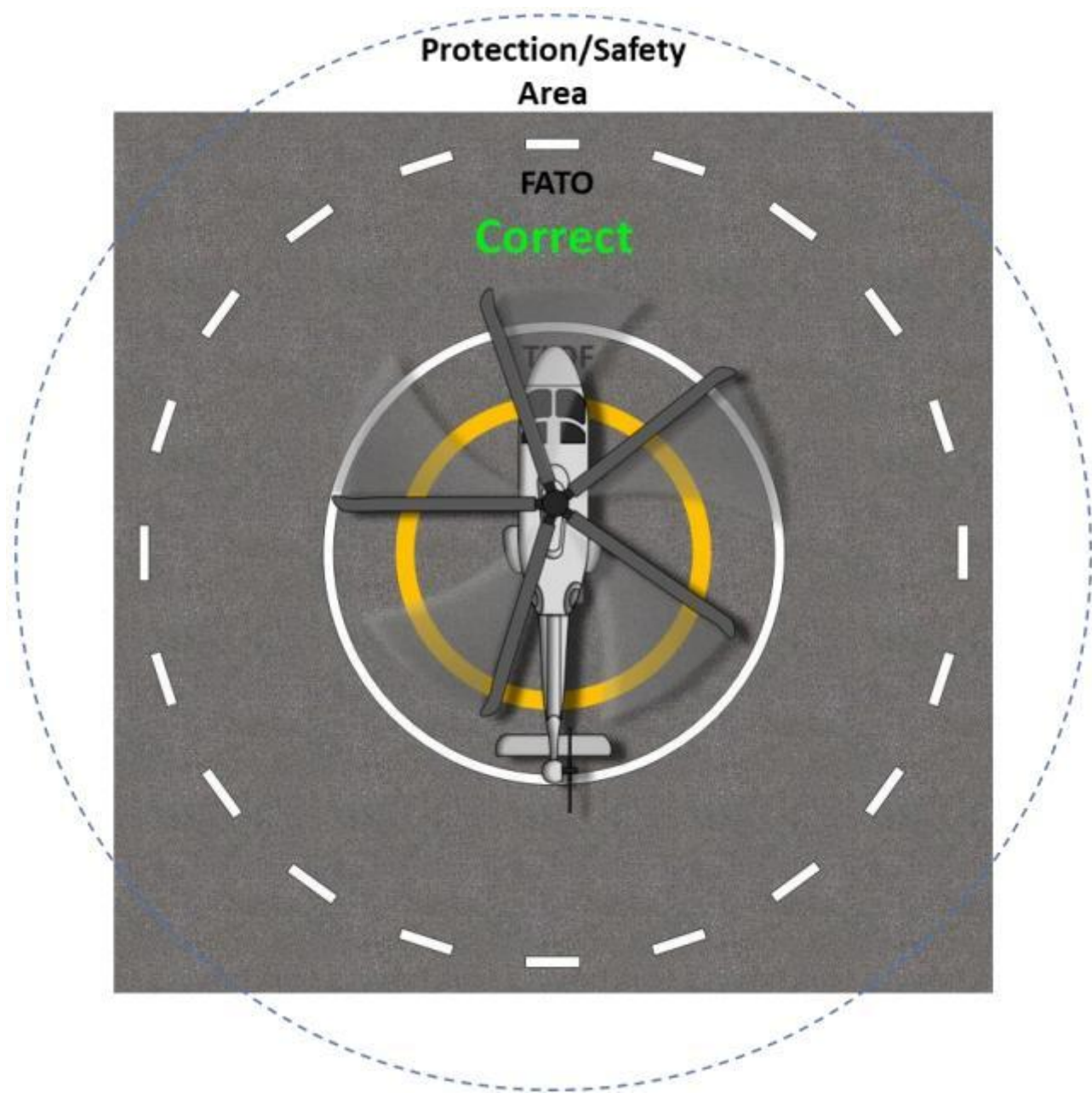

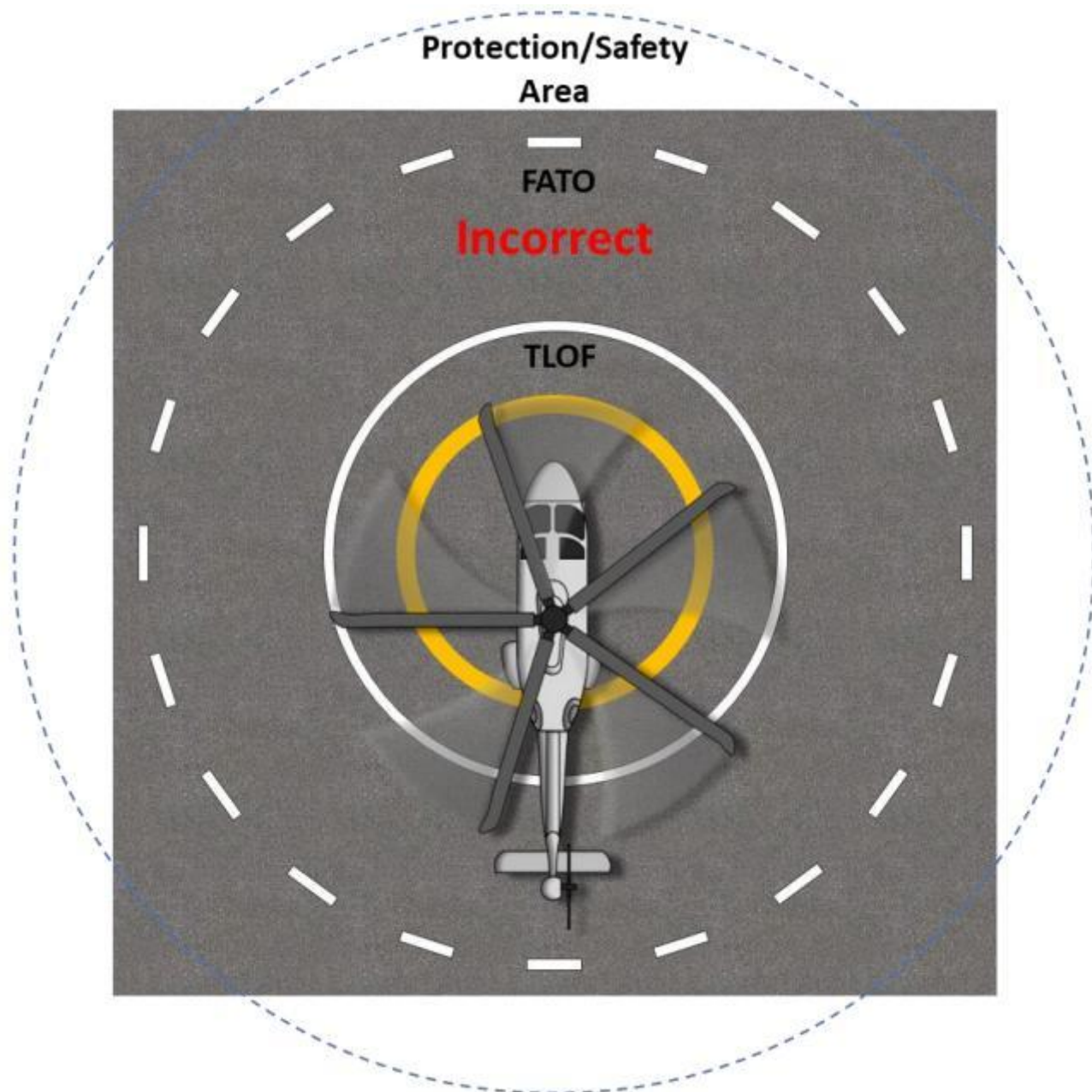

Figure 32: Correct touch down alignment over the TDPC vs incorrect alignment touch down on the "H" marking (source: CASA)

5.4 Marking the taxiways and taxi-routes

5.4.1 Ground taxi routes

5.4.1.1 A paved taxiway for ground taxiing should be marked in the same manner as described in Part 139 MOS Chapter 8.

5.5.1 General

5.5.1.1 Aprons design to accommodate vertical flight aircraft should be marked.

Note: Part 139 MOS requires that on a sealed, asphalt or concrete apron taxi guideline and parking positions must be marked for aircraft greater than 5,700 kg. Due to the nature of hazards like DW/OW and tail rotors, aerodrome operators should assess if vertical flight aircraft aprons for aircraft 5,700 kg or less should be marked.

5.5.1.2 Vertical flight aircraft apron markings should consist of:

- apron and/or stand perimeter marking
- a touch down position marking (either a TDPC or TDPS)
- lead in/lead-out markings.

optionally:

- an alignment line
- a stand designation marking
- stand limitation markings
- apron safety lines.

The specifications for stand markings listed above can be found in AC 139.R-01 and AC 139.V-01 Chapter 5, unless otherwise specified herein.

5.5.1.3 Generally, stand and apron guidance markings should be yellow in colour.

5.5.1.4 Contradictory or confusing overlapping markings should be avoided.

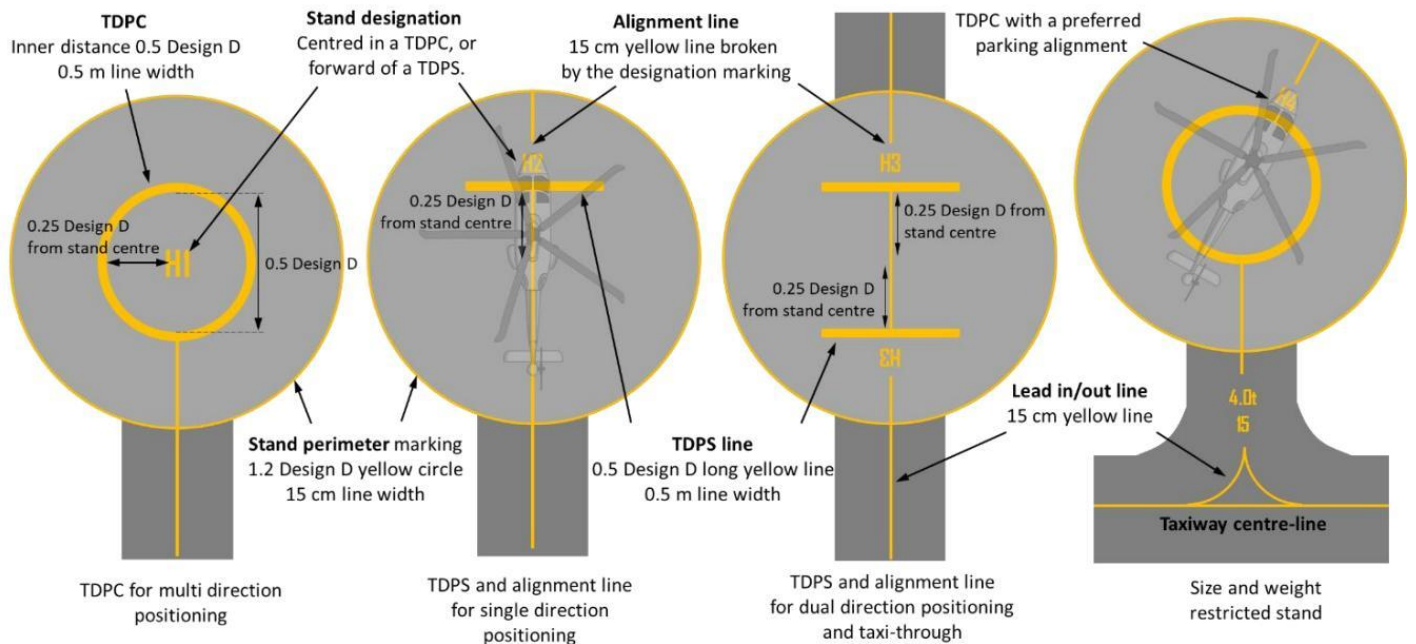

Figure 34: Stand layouts. (Source: CASA)

5.5.1.5 Figure 34 shows the general layout for D-value stand markings showing TDPC, TDPSs, stand perimeter, alignment lines and stand restriction markings. Image is for illustration purposes only; stands are not correctly spaced from each other.

5.5.2 Apron and stand perimeters

5.5.2.1 An aerodrome apron exclusively for vertical flight operations should be clearly distinguishable from a fixed-wing apron.

5.5.2.2 On a paved apron the parking clearance line (usually marked by yellow-red-yellow continuous line) should instead be marked by:

- a. double blue lines 0.15 m wide and 0.15 m apart
- b. the text "HELICOPTER ONLY":
 - i. marked in yellow letters 0.5 m high along the edge of the marking, and 0.15 m outside the vertical flight aircraft apron
 - ii. legible to pilots of approaching aircraft
 - iii. repeated at intervals not exceeding 50 m along the vertical flight aircraft apron edge marking.

5.5.2.3 On an unpaved surface, a vertical flight aircraft exclusive apron should have its edges marked by blue cones evenly spaced 30-60 m apart. Corners of the apron may be highlighted by using 3 cones set in a 90-degree pattern to each other.

5.5.2.4 A stand perimeter marking may be included (see Figure 34), this will provide pilots and ground crew with an indication of the stand containment area.

5.5.3 Touchdown positioning markings

5.5.3.1 A touch down positioning marking (TDPM) should be provided to each vertical flight aircraft stand, whether a stand is used for ground taxi or air-taxi to and from the stand.

5.5.3.2 For ground taxiing aprons where the stand is designed for either a through taxi or a taxi-on and push off, then the recommended TDPM is a TDPS.

5.5.3.3 For stands that accommodate air-taxiing aircraft or that require an aircraft to turn on the stand (either on the ground or in the air) then the stand should be marked with a TDPC.

5.5.3.4 For geometry based VCA stands a TDPS should be used in the same manner that a stop line is used for a fixed wing aircraft.

5.5.3.5 On a geometry based stand the TDPS should be positioned based on the shoulder position of the pilot of the design vertical flight aircraft (in this case being the aircraft with the greatest distance from the pilots' shoulder position to the nose of the aircraft).

5.5.3.6 When marked in the correct location, all aircraft types for that stand should fit within the footprint of the design vertical flight aircraft (for this, the design vertical flight aircraft will be the amalgamation of the geometrical shapes of all the aircraft types for that stand.)

5.5.4 Stand designation numbers

5.5.4.1 Where multiple stands need to be identifiable, stand designation markings (as seen in Figure 34) should be used. For vertical flight aircraft exclusive stands these should be ordinal numbers preceded by the letter H or other suitable identifier.

5.5.4.2 For stands with a TDPC the designation should be centrally positioned within the TDPC, or if there is a preferred alignment then located on the outside of the TDPC along with an alignment line.

5.5.4.3 For stands with a TDPS the stand designation should be positioned on top of the shoulder line centred with the alignment line, so the pilot can read the marking as they enter the stand.

5.5.4.4 The marking should be marking in a font and size that is large enough to be read by the pilot when approaching the stand but not less than 0.5 m in its longest dimension.

5.5.4.5 The alignment line should be broken either side of the designation marking.

5.6 Vertical flight visual aids - Lighting

5.6.1 General

Where the Part 139 MOS does not provide for the necessary visual aid for the intended operations of vertical flight aircraft, specifications for the lighting described in this chapter can be found in Chapter 5 Visual Aids of either AC 139.R-01 or AC 139.V-01.

5.6.1.1 Where vertical flight aircraft operations are conducted at night to facilities at an aerodrome then those facilities should be lit.

Note: This may include both vertical flight specific facilities and fixed wing aerodrome facilities being used at night for vertical flight aircraft operations.

5.6.1.2 The photometrics for vertical flight facility lights and lighting elements (including light output, vertical and horizontal distribution, and chromaticity), at an aerodrome, should be appropriate to

DRAFT

Guidelines for vertical flight aircraft facilities at aerodromes designed for aeroplanes

the aerodrome environment and intended operations without being visually distracting or confusing to pilots.

5.6.1.3 If the operating environment varies and if needed, lighting systems should be adjustable to achieve the appropriate intensity.

5.6.1.4 In cases where operations into a vertical flight facility at an aerodrome are to be conducted at night with night vision imaging systems (NVIS), it is important to ensure lighted facilities are compatible with the NVIS through the addition of technologies capable of emitting an IR signature. Where the addition of infrared emitters is not practicable, helicopter operators using NVIS should be warned to use extra caution.

5.6.1.5 Aerodrome operators that have vertical flight facilities with pilot activated lights (PAL) may choose to:

a. include that facility lighting on the same PAL frequency

or

b. provide that specific facility lighting on a separate PAL frequency.

Notes:

1. Having a separate PAL frequency may be useful where vertical flight aircraft operators are using NVIS but the aerodromes legacy (fixed-wing) facilities are not NVIS compatible but where the vertical flight specific facility lighting is.
2. Vertical flight aircraft operators would then have the option of only selecting the NVIS compatible vertical flight aircraft facilities while leaving the rest of the aerodrome lighting off thus reducing glare and distraction for the pilot.

5.6.1.6 Vertical flight facilities at an aerodrome may have a combination of the following lighting systems:

- approach lighting system
- flight path alignment guidance lights
- FATO perimeter
- aiming point lights
- TLOF perimeter lights
- TDPC lighting.

5.6.2 FATO lighting

5.6.2.1 A FATO (including when a runway is nominated as a FATO) at an aerodrome intended for night operations by vertical flight aircraft should:

- a. where a runway is nominated at the FATO, be lit by runway edge lighting as described in Chapter 9 of the Part 139 MOS
- b. in all other cases be lit by combinations of:
 - i. FATO perimeter lights
 - ii. TLOF perimeter lights

iii. aiming point lights

iv. TDPC lighting segments.

Where it is desirable and practicable to indicate a preferred approach direction to FATO then the FATO lighting above may be supplemented by:

a. an approach lighting system

or

b. flight path alignment guidance lights.

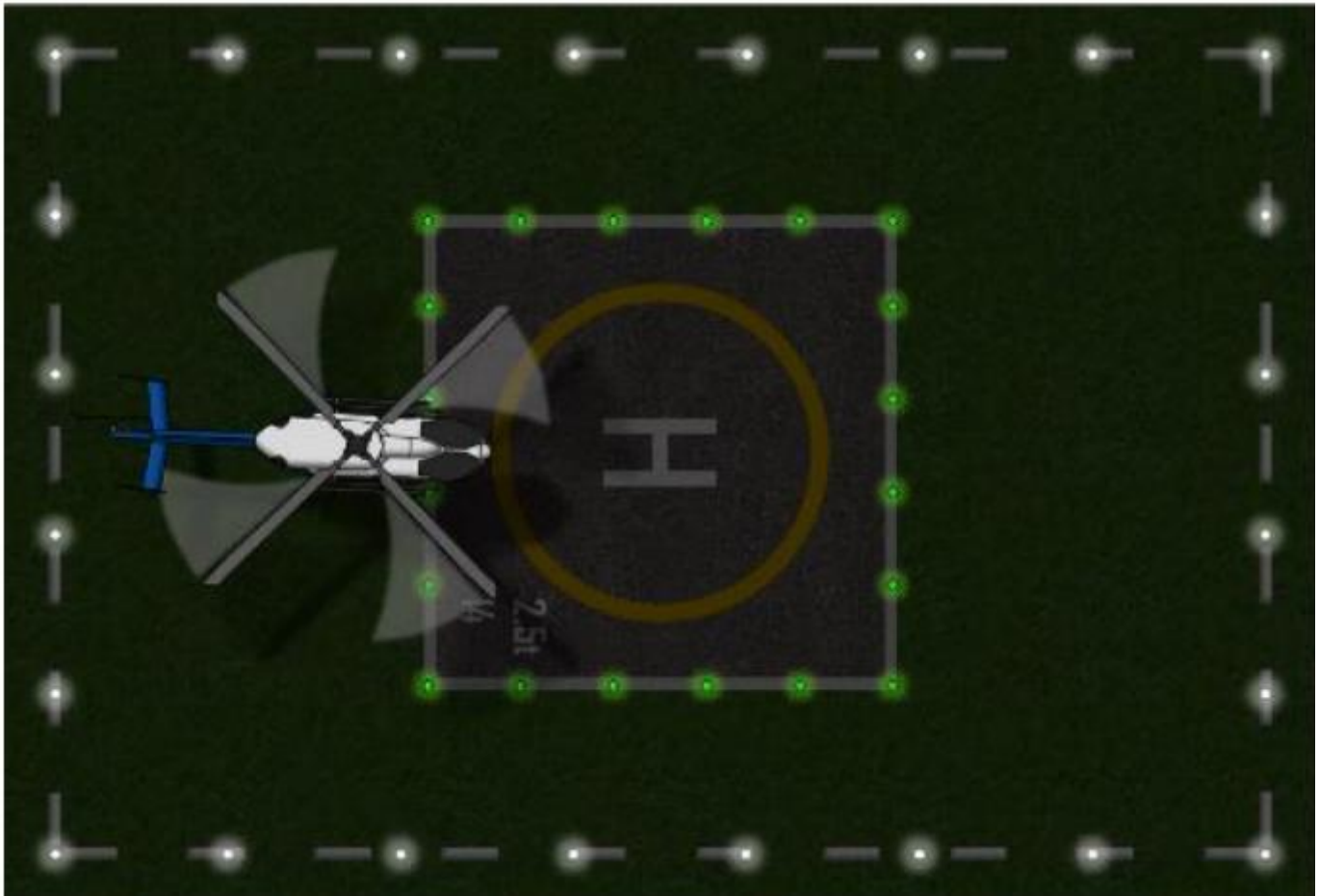

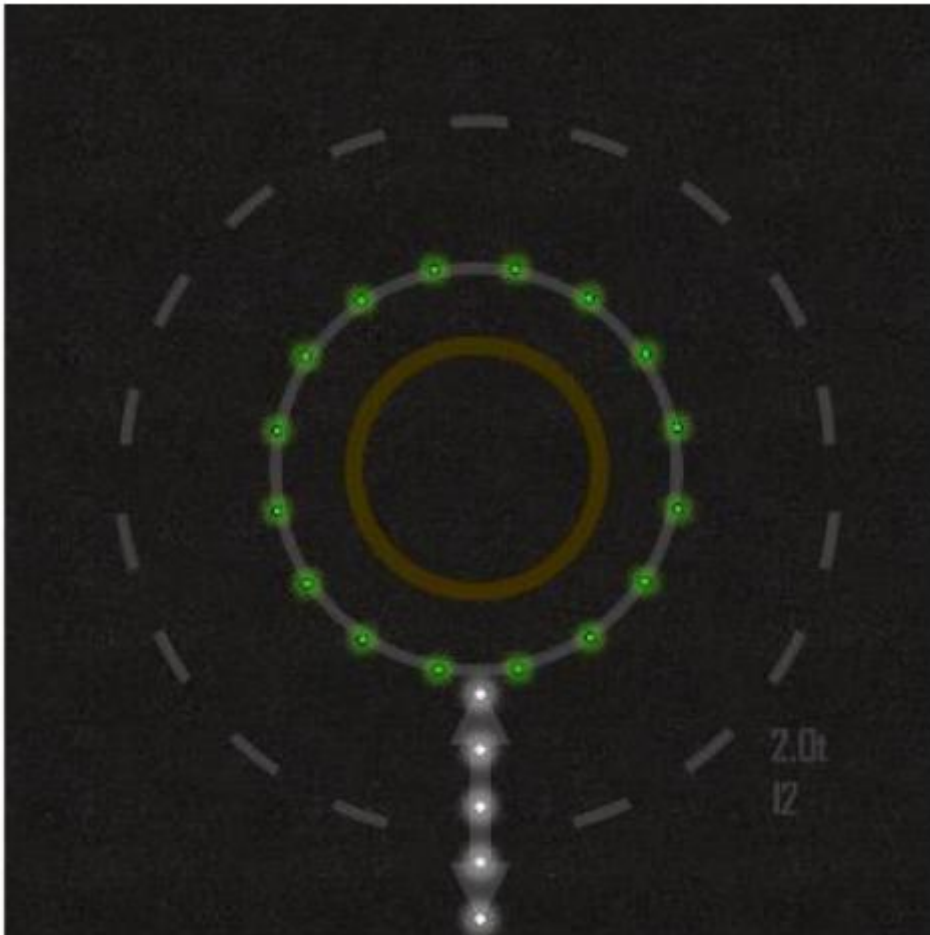

Figure 35: Lighting for FATOs with a TLOF (Source: CASA)

5.6.2.3 Figure 35 shows examples of lighting for FATOs with a TLOF. Showing FATO perimeter lights (left) and flight path alignment lights (right) in white, and both with the TLOF lit in green.

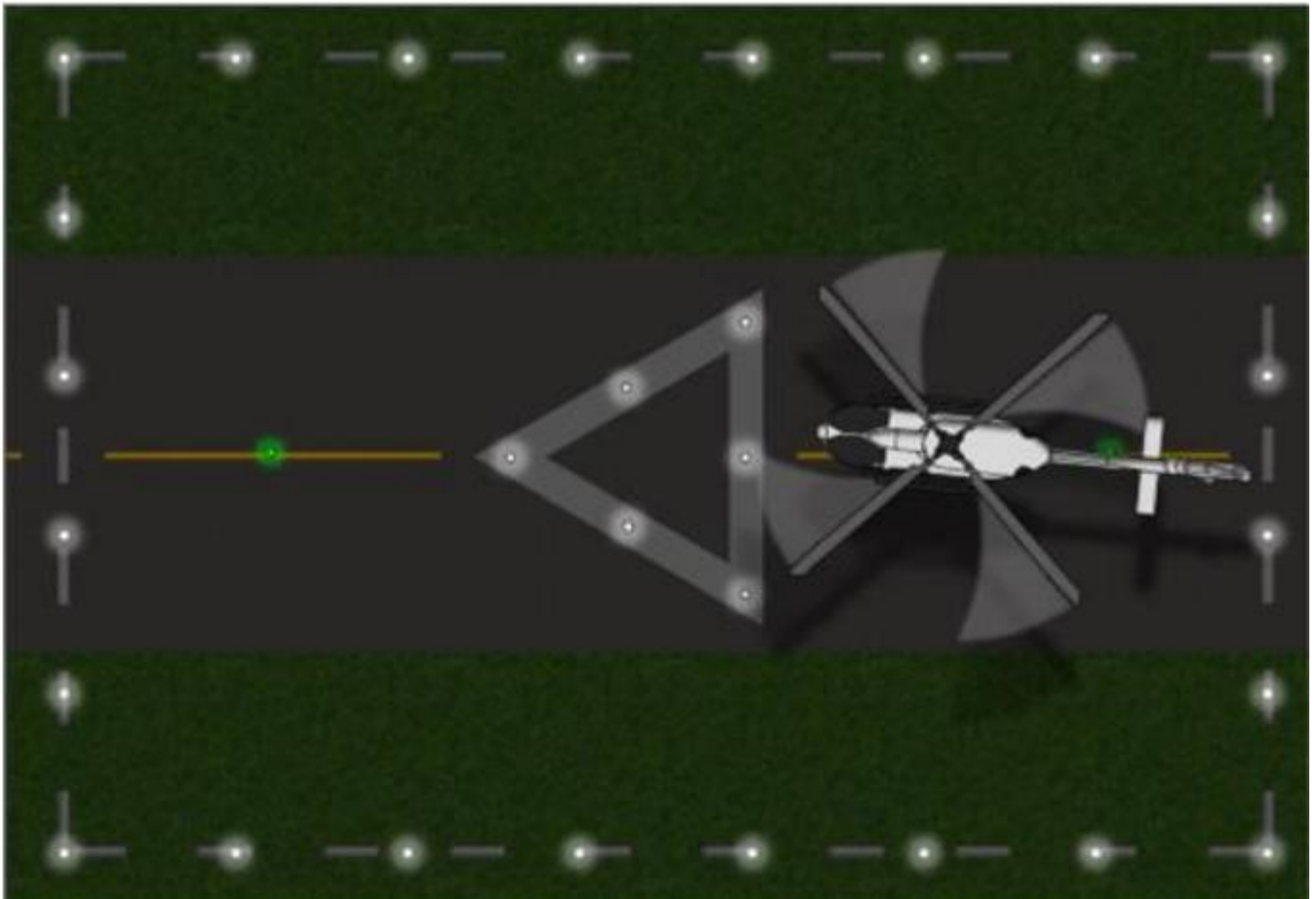

Figure 36: Lighting for FATOs on taxiways (source: CASA)

5.6.2.4 Figure 36 shows examples of lighting for FATOs on taxiways, one with FATO lights and an aiming point in white, and one with flight path alignment lights and a TDPC with yellow lighting segments.

5.6.3 Taxiway and taxi route lighting

5.6.3.1 Taxiways used at night for vertical flight operations, for ground taxi or an aligned air-taxi route, should be lit by either taxiway edge or centreline lighting.

Refer to Chapter 9 or the Part 139 MOS for taxiway lighting specifications.

5.6.3.2 Where there is an air taxi-route, not aligned with a taxiway then, due to the risk of a fixed-wing aircraft inadvertently turning off the paved surface:

DRAFT

Guidelines for vertical flight aircraft facilities at aerodromes designed for aeroplanes

a. when other vertical flight taxi-routes (aligned with lit taxiways) are available, the non-aligned taxi-route should be published as not available for night ops

or

b. some form of guidance should be provided to indicate the end of pavement to aircraft taxiing on the ground, such as:

i. Information only movement area guidance signs stating text such as "AIR TAXI"

ii. use of pavement edge markings.

6 Published information

6.1 Vertical flight aircraft facility data

6.1.1 Data specifications

6.1.1.1 Aerodrome operators should publish data as required under Part 175 of CASR.

6.1.1.2 If data product specifications are not available from the AIS provider, then data and information for vertical flight facilities on an aerodrome should be published in accordance with the data product specifications available in ICAO Doc 10066.

6.1.1.3 ICAO Doc 10066 contains the required data specifications for:

- FATO
- TLOF
- safety(protection) areas
- helicopter clearways
- helicopter ground taxiway
- helicopter air taxiway
- helicopter air transit routes
- helicopter stands.

6.1.2 Data requirements in Part 139 MOS

6.1.2.1 Aerodrome operators should publish the following vertical flight facility data for the AIP and their aerodrome manual.

- On the aerodrome diagram, the location of FATO/s:
 - runway type
 - FATO containing a TLOF
 - FATO containing an aiming point.

Refer to Division 1 of Chapter 5 of the Part 139 MOS for standards for published information

Suggested vertical flight facility symbology

6.1.2.2 The range of options below will provide pilots with information on the specific vertical flight facilities available at an aerodrome.

6.1.2.3 Runway type FATO symbols should be shown:

- a. with their designation and "H" at each end
- b. with the FATO length, in meters, written below the symbol
- c. if sealed, as a solid black rectangle
- d. if unsealed a white rectangle with black outline.

6.1.2.4 Conventional (Non-runway) FATO symbols should be shown:

- a. notated with any designation (e.g. Southern FATO)
- b. orientated with the approach direction, where applicable
- c. when associated with a TLOF, as an H in a circle
- d. when the FATO only has an aiming point only and no TLOF, shown as an H in a triangle
- e. if sealed, as a solid black icon with white text
- f. if unsealed, as a white icon with black text.

EXAMPLE ONLY

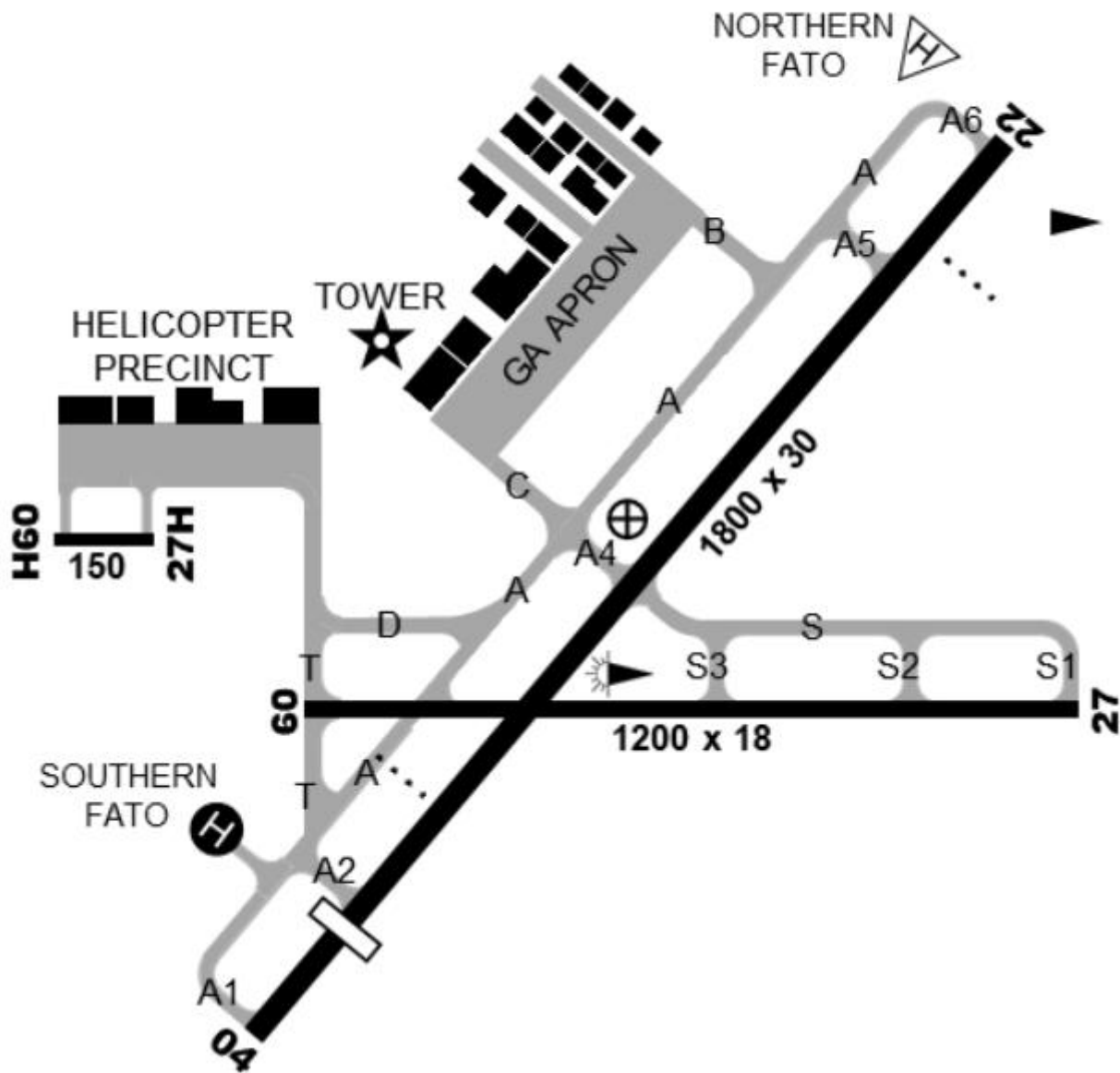

Figure 37: Fictional aerodrome diagram (Source: CASA)

6.1.2.5 Figure 37 shows a fictional example of an aerodrome diagram showing a runway type FATO, a paved FATO (with TLOF) and an unpaved FATO with no TLOF (aiming point only).

FATO

Sealed



Unsealed



Aiming Point



Runway type FATO

Sealed



Unsealed

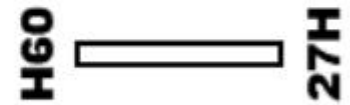

Figure 38: A key showing the different iconography for depicting FATOs on an aerodrome diagram. (Source: CASA)

6.1.3 Aerodrome manual data

6.1.3.1 The operator of a certified aerodrome with vertical flight facilities should record all published data in their aerodrome manual.

6.1.4 Declared distances for vertical flight facilities

6.1.4.1 The declared distances specified below are normally associated with a runway type FATO and are generally going to be associated with helicopters that are operating to a performance category. They may be applicable to future VCA operations.

6.1.4.2 Declared distances for non-runway type FATOs may be published in a slightly modified form¹⁵.

Take-off distance available (helicopter or VCA)

6.1.4.3 Take-off distance available (TODAH or TODAV) means the length of the FATO plus the length of helicopter clearway (if provided) declared available and suitable for helicopters to complete the take-off.

6.1.4.4 Where a clearway is provided then the TODAH/TODAV will be the FATO length, the length of the clearway, plus the safety/protection area that is located between the two.

Refer to AC 139.R-01 section 4.1 for details on helicopter clearways.

Rejected take-off distance available

6.1.4.5 Rejected take-off distance available (RTODAH or RTODAV) will be length of the FATO declared available and suitable for helicopters operated in certain performance classes.

Landing distance available

6.1.4.6 Landing distance available (LDAH or LDAV) is the length of the FATO plus any additional area declared available and suitable for helicopters to complete the landing manoeuvre from a defined height.

Note: Where a FATO is provided that is not suitable for supporting the dynamic weight of an aircraft, such as non-weight bearing grass, or a FATO over water, then all declared distances will be determined by the dimensions of the TLOF.

15 Refer to

Figure 39: Visual explanation of declared distances for different FATO types. (Source: CASA)

DRAFT

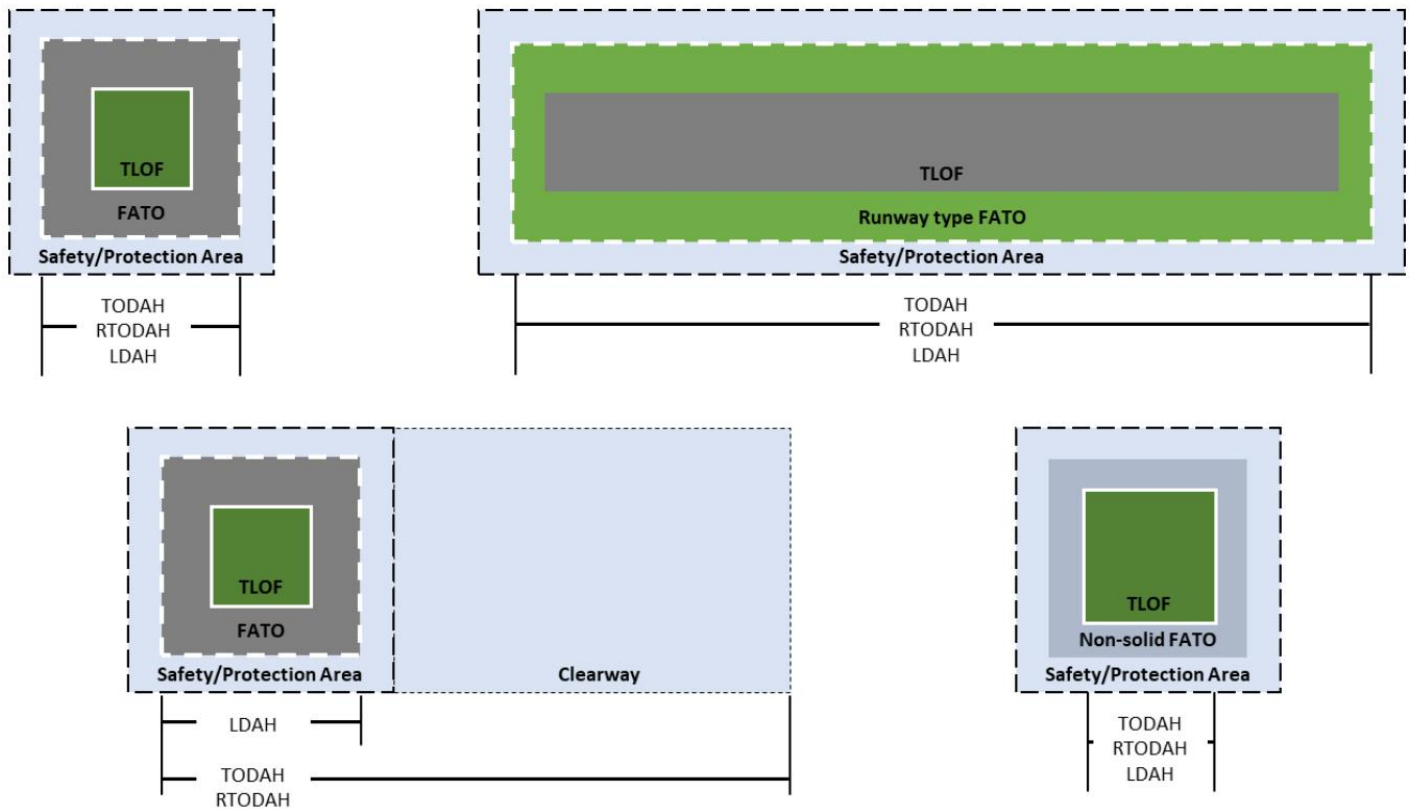

Figure 39: Visual explanation of declared distances for different FATO types. (Source: CASA)

6.1.5 Suggested ERSA data

6.1.5.1 Where an aerodrome has specific vertical flight facilities then publishing the following data into ERSA should be considered by the aerodrome operator.

6.1.5.2 The data provided should be consistent with the DPS requirements

6.1.5.3 For each FATO, the following information is suggested (refer to the blue annotations on Figure 40):

a. Designation:

i. Runway FATO designation or FATO identifier.

b. FATO bearing in degrees magnetic for preferred approach

c. TLOF length:

i. For a runway FATO - the TLOF length in meters

ii. for a FATO with TLOF - the TLOF dimensions in meters

iii. for a FATO with an aiming point- Note stating "Aiming point only"

d. TLOF surface:

i. asphalt

ii. concrete

iii. other surface (always to be qualified by a note)

e. TLOF pavement strength rating:

i. Report pavement strength using the ACR/PCR rating system

ii. or the maximum weight and tyre pressure

Guidelines for vertical flight aircraft facilities at aerodromes designed for aeroplanes

iii. For a FATO with an aiming point then this line should state 'touch down not permitted'

f. FATO width and surface:

i. runway FATO - both the width of the TLOF and the width of the FATO in meters

ii. the FATO length and width in meters

iii. the FATO surface description.

6.1.5.4 Lighting specifically associated with vertical flight aircraft FATOs and TLOFs should also be published in ERSA in the same format as aerodrome and approach lighting are described in the ERSA Introduction. Vertical flight lighting facilities may use the abbreviations in Table 15 below.

Table 15: Vertical flight lighting facility abbreviations for ERSA

APL	Aiming point lights
FALS	FATO Approach Lighting System
FPAGL	Flight Path Alignment Guidance Lights
FPLS	FATO Perimeter Lights
TPL	TLOF Perimeter Lights
TLS	TLOF Lighting Segments
TDPL	Touch Down Position Lights
VAGS	Visual Alignment Guidance System
HVASI	Helicopter Visual Approach Slope Indicator

6.1.5.5 Aerodrome operator may choose to publish specific operations for vertical flight aircraft in their local traffic regulations section of the ERSA.

6.1.6 Suggested runway distance supplement (RDS) data

6.1.6.1 For each FATO, the following information is suggested (refer to the blue annotations on Figure 40):

- a. FATO Designation for each FATO
- b. Design D:
 - i. The design D is provided for each FATO listed.
- c. The TORAH, RTODAH and LDAH for each FATO (refer to 6.1.4 and Figure 40):
 - i. For a FATO with an aiming point only the RTODAH should be published
 - ii. TLOF and FATO widths should be published for runway type FATOs.

Guidelines for vertical flight aircraft facilities at aerodromes designed for aeroplanes

AIP Australia		## JUN 202#		FAC YEXP - 4		ELEV 99	
EXAMPLE AERODROME							
... (sections omitted for clarity)							
EXAMPLE ONLY							
... (sections omitted for clarity)							
PHYSICAL CHARACTERISTICS							
04/22	035	59a	... (further text omitted for clarity)				
09/27	095	39a	...				
VERTICAL FLIGHT FACILITIES							
a	b	c	d	e	f		
N FATO	215	Aiming point only	(c) Touch down not permitted	FATO 25 x 25 m (grass)			
S FATO	035	14 x 14 m (b)	5700 552(80PSI)	FATO 25 x 25 m (concrete)			
09H/27H	095	150 m (a)	PCN 8 /F/C /1275(185PSI) /U	WID TLOF 17 FATO 35			
(c) – grass, not for touch down							
AERODROME AND APPROACH LIGHTING							
RWY04/22	MIRL	... (further text omitted for clarity)					
LIGHTING - VERTICAL FLIGHT FACILITIES							
N FATO	FPL	PAL 123.4	STDY PWR AVBL				
N FATO	APL	PAL 123.4	STDY PWR AVBL				
S FATO	FPL	PAL 123.4	STDY PWR AVBL				
S FATO	TDPL(1)	PAL 123.4	STDY PWR AVBL				
09H/27H	TPL	PAL 123.4	STDY PWR AVBL				
09H/27H	HVASI	PAL 123.4	6.0 DEG 75FT	STDY PWR AVBL			
(1) TDPC LGT: yellow segment lights							
... (sections omitted for clarity)							
LOCAL TRAFFIC REGULATIONS							
GENERAL							
1. ... (text omitted for clarity)							
g) Aircraft 7000 kg and below arriving RWY 22 behind a helicopter arriving to northern FATO, caution helicopter wake turbulence.							
... (sections omitted for clarity)							
5. HELICOPTER OPS							
a) DAY HEL operations over 7000 kg or PC 1 must use 09H/27H only.							
b) NGT OPS shall comply with fixed wing circuits and ALTs and shall ARR and DEP to the operational RWY.							
c) Helicopters arriving and departing northern FATO must air transit to the helicopter precinct by the published air transit route only.							
d) Pilots must nominate the FATO they wish to use on initial contact with ATC.							
EXAMPLE ONLY							

Figure 40: Vertical flight data for ERSA and RDS. (Source: CASA)

6.1.6.2 Figure 40 shows a fictitious example of published ERSA facilities and RDS for vertical flight operations at a fictitious aerodrome. The ERSA entries describe the physical characteristics and lighting for 3 FATOs, as well as the permitted ground taxi and air-transit routes. Annotations in blue are explained in paragraph 6.1.5 and paragraph 6.1.6.

6.1.7 Vertical flight ground movement charts

6.1.7.1 Where an aerodrome wishes to specify ground taxi-routes, air-taxi routes, air transit route, or where they wish to allow or prohibit vertical flight aircraft operations from using a particular area(s), then an aerodrome operator may choose to publish a helicopter specific ground movement chart.

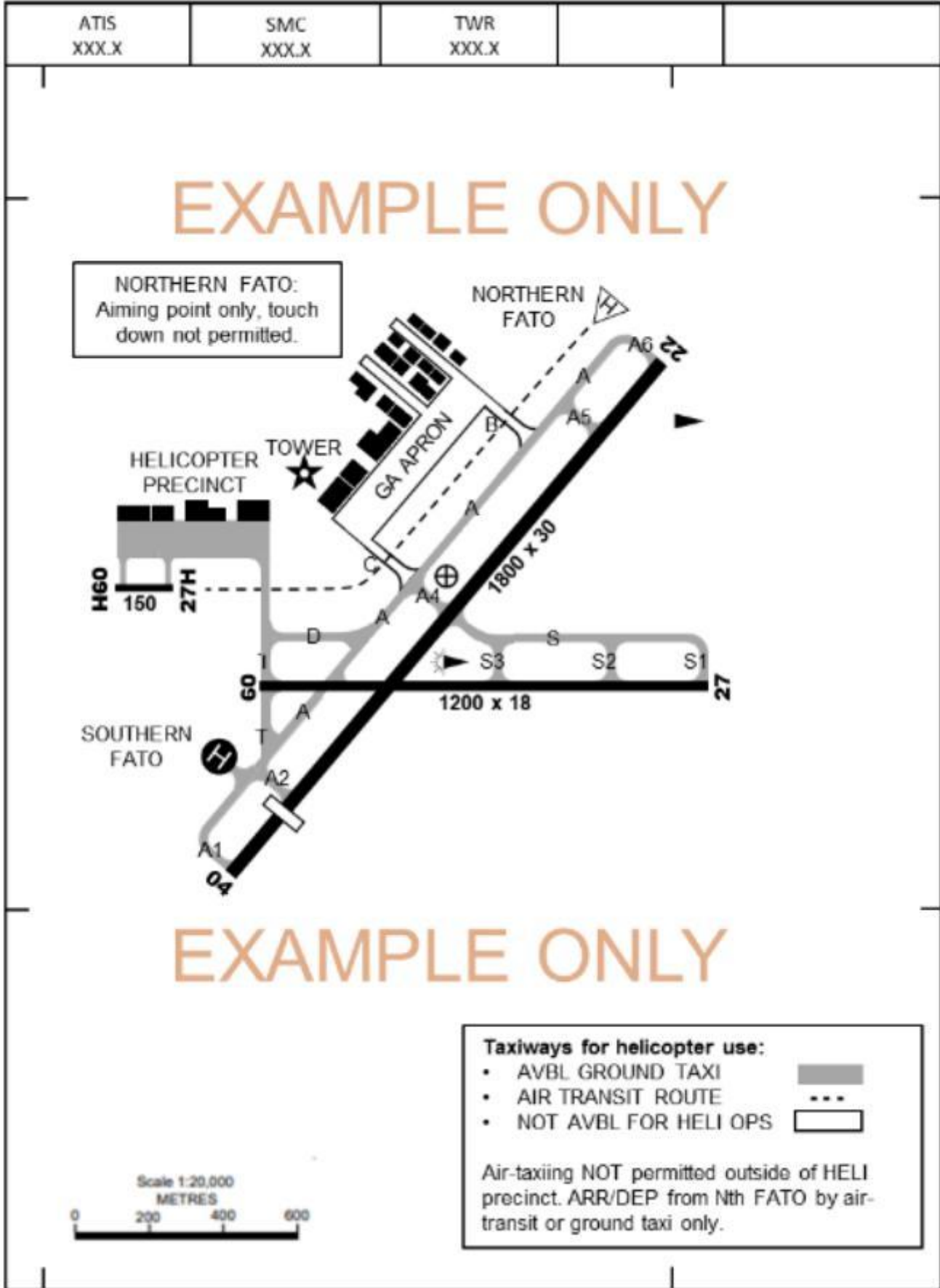

Figure 41: Ground movement chart. (Source: CASA)

6.1.7.2 Figure 41 shows a fictitious example of published ground movement chart for available the

air transit route and prohibited area for vertical flight aircraft movements at a fictitious aerodrome.

☐☐ #4

☐ Admin ☐☐ 2026-05-30 23:13:52 CST

☐ Admin ☐☐ 2026-05-30 23:33:27 CST