

1.2 Rotor Diameter (RD) ????

- 20. *Rotor Diameter (RD)*: The largest length of all the rotors from tip to tip. It can be computed by finding the diameter of the smallest circle enclosing all the lift producing propulsion units, including their propellers, rotors, fans, etc., on a horizontal plane, while the aircraft is in the vertical takeoff or landing configuration, with rotors/propellers/fans turning, if applicable. The RD must also incorporate all landing gear and surface touch points. See [Figure 1-1](#).
- 21. *Safety Area*: The Safety Area is a defined area surrounding the FATO intended to reduce the risk of damage to aircraft accidentally diverging from the FATO.
- 22. *Translational Lift*: Translational lift is the improved rotor/propeller efficiency resulting from directional flight.
- 23. *Touchdown and liftoff area (TLOF)*: The TLOF is a load-bearing, generally paved, area centered in the FATO on which the aircraft performs a touchdown or liftoff.

FAA EB105A D RD D VTOL aircraft RD lift-producing propulsion units landing gear / surface touch points FATO/TLOF RD Safety Area D

2. FAA AC150/5390-2D??? heliport ????

FAA-AC-150-5390-2D-Heliport-Design.pdf

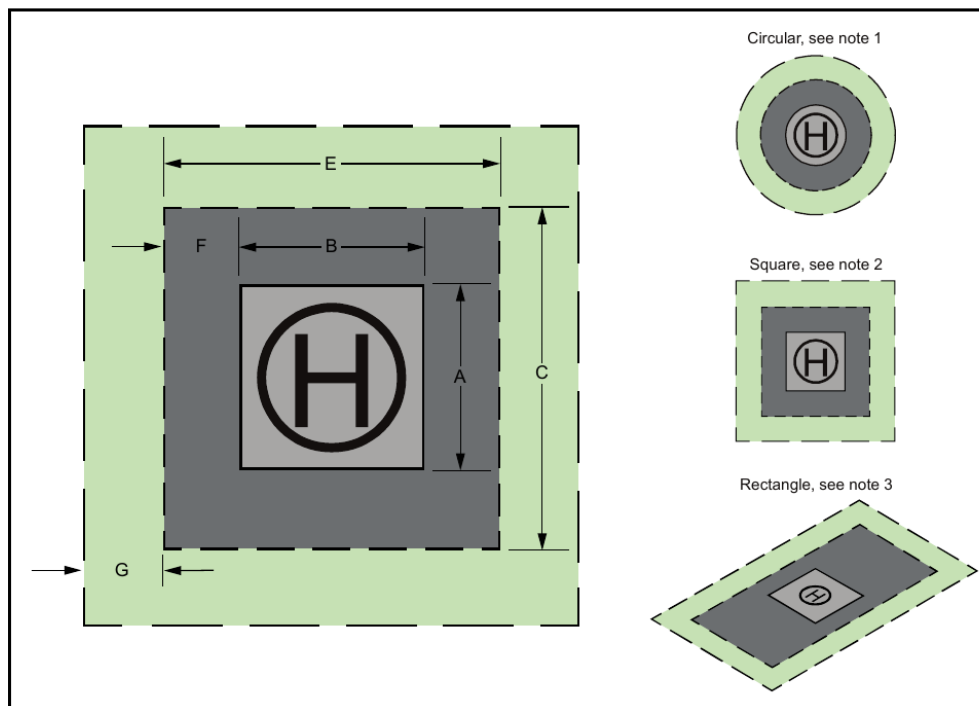

3. EASA PTS-VPT-DSN? Dimension D

EASA-PTS-VPT-DSN-current-official.pdf

- rejected take-off distance (RTOD), characteristics of the load-bearing surface needed for rejected take-off (RTO);
- landing gear geometry and dimensions, minimum ground turn radius;
- VTOL taxiing, ground movement and parking requirements (specify the moving infrastructure for VTOL-capable aircraft, and whether the 'D-value' changes from landing to taxiing and parking);
- visual angle in the vertical plane through pilot eye position (examples: Figures 2 and 3);
- possible impact of battery charging/swapping procedures on taxiway and parking position design requirements;
- downwash protection area to be considered (to allow safe operation and minimise hazards for ground personnel);
- Note: To support the drafting of VPT-DSN specifications, the following information on the radial component of the downwash ('outwash') is required: VTOL manufacturers should report if while the aircraft is in a low hover at the limits of a cylinder volume of diameter $2D$ around the VTOL-capable aircraft / from the ground/surface up to 1.5 m of height, the maximum measured radial speed is lower than 60 km/h in any wind conditions within the VTOL limit flight envelope (see [EASA SC-VTOL-01](#), VTOL.2135). If the downwash temperature at those limits of the cylinder volume is more than 10°C above the ambient temperature, this should be also reported); and
- minimum handling-area requirements around the VTOL-capable aircraft, including passenger handling and areas anticipated for the VTOL-capable aircraft services (i.e. battery charging,

EASA D /

VTOL aircraft

3.1 FATO / TLOF ????

- (f) When designing VTOL-capable aircraft stands, the location and dimensions of the charging facility should be taken into consideration.

PTS VPT-DSN.C.210 Final-approach and take-off areas (FATOs)

- (a) An FATO should:

- (1) provide:

- (i) an area free of obstacles (except for essential objects which because of their function are located on it), and of sufficient size and shape to ensure containment of every part of the design VTOL-capable aircraft in the final phase of the approach and at the commencement of the take-off in accordance with the intended procedures;

Note: Essential objects are visual aids (e.g. lighting or roll-over protection if the vertiport is elevated) or other aids (e.g. firefighting systems) necessary for safety purposes; and

- (ii) when solid, a surface resistant to the effects of downwash, which:

- (A) when collocated with a TLOF, is contiguous and flush with the TLOF, has a bearing strength capable of withstanding the intended loads, and ensures effective drainage; or
- (B) when not collocated with a TLOF, is free of hazards, should a forced landing be required;

the undercarriage of the most demanding VTOL-capable aircraft the TLOF is intended to serve in accordance with the intended orientation;

- (ii) a surface which:
 - (A) has sufficient bearing strength to accommodate the dynamic loads associated with the anticipated type of arrival of the VTOL-capable aircraft at the designated TLOF;
 - (B) is free of irregularities that would adversely affect the touchdown or lift-off of VTOL-capable aircraft;
 - (C) has sufficient friction to avoid skidding of VTOL-capable aircraft or slipping of persons;
 - (D) is resistant to the effects of downwash; and
 - (E) ensures effective drainage while having no adverse effect on the control or stability of a VTOL-capable aircraft during touchdown and lift-off, or when stationary; and
- (2) be associated with a FATO, a portion of a taxiway or a stand.
- (d) The minimum dimensions of a TLOF should be 0.83 D or the dimensions for the required procedure prescribed in the AFM of the VTOL-capable aircraft for which the TLOF is intended, whichever is greater.
- (e) For a vertiport that is elevated, the minimum dimensions of a TLOF, when in a FATO, should be of sufficient size to contain a circle of diameter of at least 1 Design D. For a non-solid FATO, TLOF should be of sufficient size to permit servicing of the aircraft.

4. CASA AC139.V-01?D / Design D / OFV ??



CASA-AC139.V-01-Guidance-Vertiport-Design-2023.pdf

下列缩略语适用于本文件。

- eVTOL: 电动垂直起降航空器 (electric Vertical Take Off and Landing)
- FATO: 最终进近和起飞区 (Final Approach and Take-Off area)
- MTOW: 最大起飞重量 (Maximum Take-Off Weight)
- OFV: 无障碍空间 (Obstacle-Free Volume)
- TLOF: 接地和离地区 (Touch Down and Lift-Off area)

5 物理特性

5.1 一般要求

- 5.1.1 eVTOL 起降场在同一时间一个最终进近和起飞区内应仅有一架 eVTOL 运行。
- 5.1.2 eVTOL 起降场应平整并确保有效排水，同时不对 eVTOL 起降或停放产生不利影响。

5.2 最终进近和起飞区

- 5.2.1 最终进近和起飞区 (FATO) 指用于电动垂直起降航空器悬停或着陆，以及开始起飞动作的特定区域。
- 5.2.2 eVTOL 起降场应至少设置一个最终进近和起飞区 (FATO)。FATO 道面应为硬质实体，且充分考虑建筑体对航空器设备的干扰等情况。实体不应在 eVTOL 下洗流的作用下造成表面退化，也不应产生飞散的碎片。
- 5.2.3 FATO 尺寸应至少能够内切一个设计机型 1.5D 的圆。
- 5.2.4 除因功能要求需设置于该区内的必要物体外，FATO 内不应有障碍物，位于 FATO 内的必要物体高度不应超过 FATO 表面以上 5 cm。
- 5.2.5 FATO 坡度应不小于 0.5%，各方向的总坡度应不超过 2%。

5.3 接地和离地区

- 5.3.1 接地和离地区 (TLOF) 指供电动垂直起降航空器接地或离地的一块承载区。
- 5.3.2 eVTOL 起降场应至少设置一个接地和离地区 (TLOF)。TLOF 位于 FATO 内，其表面应与 FATO 连续顺接，道面应为硬质实体，且充分考虑建筑体对航空器设备的干扰等情况。实体不应在 eVTOL 下洗流的作用下造成表面退化，也不应产生飞散的碎片。
- 5.3.3 TLOF 尺寸应至少能够内切一个设计机型 1.0D 的圆。
- 5.3.4 除因特定功能需要而设置在 TLOF 内的物体，TLOF 内不应有障碍物。如位于 TLOF 内的必要物体高度不超过 2.5 cm 且边缘具有倒角，同时不对 eVTOL 运行构成危险，则可不被视为障碍物。
- 5.3.5 TLOF 应在坡度设置上与 FATO 保持一致。
- 5.3.6 TLOF 表面应有足够的摩擦性能，避免 eVTOL 滑移或人员滑倒。

□□□□□□□□□□ FATO 1.5D □ TLOF 1.0D □□□□□□□□ eVTOL □□□□□□□□□□□□□□□□□

6. MH5013-2023????? D / RD ??

□□□ □□□□□□□□□□□□□□ -MH5013-2023.pdf

2.1.11 直升机机身宽度 (W_f) fuselage width of helicopter

直升机机身（不含旋翼、短翼、起落架、水平安定面及尾桨）的宽度。

2.1.12 直升机全尺寸 (D) over-all length/width of helicopter

直升机全长和全宽中的较大值。

2.1.13 直升机起落架横距 (UCW) width of the undercarriage of helicopter

轮式直升机主起落架横向外轮间距，或撬式直升机起落架横向间距。

【条文说明】2.1.8~2.1.13 所描述的直升机主要尺寸位置示意如图 2.1.13 所示。

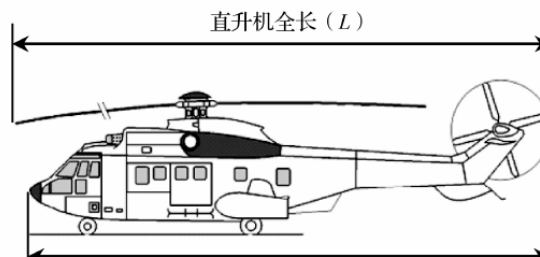

□□□□ MH5013 □ D □□□□□□ RD □□□□□□□□□□ eVTOL □□□ D
 □□□□□□□□ MH5013 □□□□□□

7. ICAO Annex 14 Volume II?FATO / TLOF ????

□□□ [ICAO-Annex-14-Volume-II-Heliports.pdf](#)

5.1 FATO ??

reduced TLOF (Figure I-3-2 refers). The FATO is bound by the outer circle from which the obstacle sector surfaces derive their origin. The TLOF is bound by the inner circle (represented as a circle within the octagon shape of the helideck load-bearing area). The FATO outside the TLOF perimeter represents a non-load bearing surface for helicopters as it usually extends over the safety device (whether safety net or safety shelf) which is incapable of supporting even the static load of a helicopter. Therefore, a helideck incorporates one FATO and one TLOF; notwithstanding for a fixed or floating offshore facility, to improve operational flexibility, there may be the possibility to provide additional helideck(s) elsewhere on the facility – the advantages of this are raised in Chapter 3, 3.2.1.10.

3.3.3 It should be remembered that the basic size of a 1 D FATO with coincident TLOF is, of necessity, a compromise for offshore operations where space is invariably limited. Nonetheless, it is essential that the TLOF provides sufficient space for the landing gear configuration and sufficient surface area to promote a helpful “ground cushion” effect from rotor downwash. The area provided should also allow adequate room for passengers and crew to alight or embark the helicopter and to transit to and from the operating area safely. In addition, space consideration needs to be given to allow essential on deck operations, such as baggage handling, tying down the helicopter or helicopter refuelling, to occur safely and efficiently, and, in the event of an incident or accident occurring, for rescue and firefighting teams to always have good access to the landing area from an upwind location (see also Chapter 6).

3.3.4 The design should allow for sufficient clearance from the main rotor and tail rotor of the helicopter to essential objects permitted to be around the perimeter of the TLOF, including obstacles that may be present in the limited obstacle sector (LOS). It should be clearly understood that a FATO of 1 D is the minimum dimension sufficient for the containment of the helicopter; in this case, where a precise landing is completed (see also Chapter 5, especially the use of touchdown/positioning marking circle), the main and tail rotors will abut the edge of the 1 D circle. For this reason it is important that the yellow touchdown/positioning marking circle is accurately and clearly marked and is used by aircrew every time for positioning the helicopter during the touchdown manoeuvre.

3.3.5 Sufficient margins to allow for touchdown/positioning inaccuracies as a result of normal variations or handling difficulties, for example due to challenging meteorological conditions, aerodynamic effects and/or dynamic motions due to ocean waves, should be allowed for in the design. The helideck and environs should provide adequate visual cues and references for aircrew to use throughout the approach to touchdown manoeuvre, from initial helideck location and identification (acquisition) through final approach to hover and to landing. In addition, adequate visual references should be available for the lift-off and hover into forward flight.

3.3.6 In consequence of the considerations stated above, except where an aeronautical study/risk assessment is

Doc 9261 1D FATO coincident TLOF sub-1D TLOF
TLOF 0.83D 1D

9. ????? / OLS / OFV ????

ICAO/MH5013 OLS EASA/CASA OFV
FAA EB105A Part 77

9.1 T/CCAATB 0062-2024?h0?D ? h0>D ? OFV



图 5.4-1 FATO、TLOF 和安全区场地物理特性示意图

5.5 机位

- 5.5.1 机位的尺寸和形状应满足 eVTOL 起降场设计机型在停放时, eVTOL 的垂直投影均包含在机位中。
- 5.5.2 机位形状为圆形, 其尺寸应至少能够内切一个设计机型 $1.2D$ 的圆, 机位与机位之间的间距应至少为 2.0 m 。
- 5.5.3 机位上宜设置满足 eVTOL 停放所需的系留设施。

5.6 地面滑行道

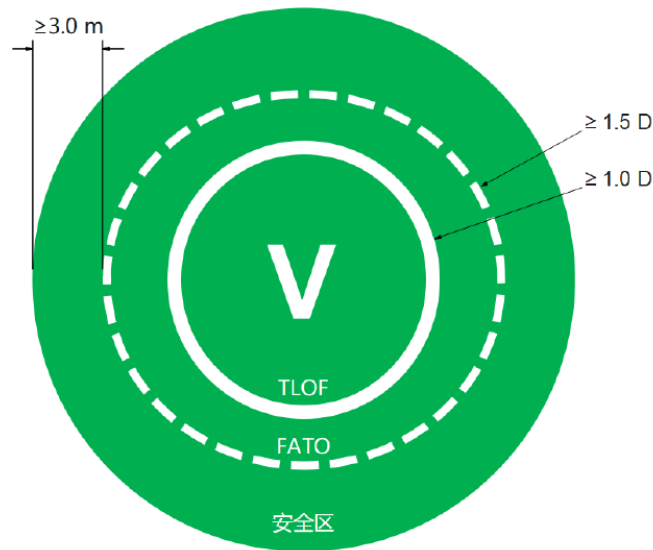
- 5.6.1 在机位与机位之间、机位与机库之间应设置地面滑行道。
- 5.6.2 地面滑行道应能承受 eVTOL 移动时的运行荷载。
- 5.6.3 地面滑行通道的宽度应不小于 eVTOL 起落架宽度或 eVTOL 转运装置最大轮外侧间距的 2 倍。

6 障碍物限制

6.1 净空条件良好时

- 6.1.1 在空域环境良好时, eVTOL 起降场障碍物限制面宜参照 MH 5013《民用直升机场飞行场地技术标准》中的规定, 并以 eVTOL 最大全尺寸 D 代替直升机最大旋翼直径。进近和起飞爬升面内边宽度为 FATO 加安全区的宽度, 内边位置为安全区边界。
- 6.1.2 eVTOL 起降场宜至少设置两个进近/起飞爬升面, 中线夹角宜不小于 135° 。

6.2 净空条件复杂时

- 6.2.1 当场址周边净空条件复杂, 或参照 MH 5013《民用直升机场飞行场地技术标准》设置障碍物限制面无法满足净空要求时, 宜考虑设置悬停高度 (以 h_0 表示) 及相应的无障碍空间 (OFV)。进近和起飞爬升面、过渡面起始端位于无障碍空间顶面, 其他参数宜参照 MH 5013《民用直升机场飞行场地技术标准》设置。

- 6.2.2 悬停高度的设置应根据周边航路上的障碍物及 eVTOL 的飞行性能确定。

示例: 以正方形 FATO 为例, 悬停高度 $h_0 \leq D$ 时的障碍限制面示意图见图 6.2-1, 悬停高度 $h_0 > D$ 时的障碍限制面示意图见图 6.2-2。

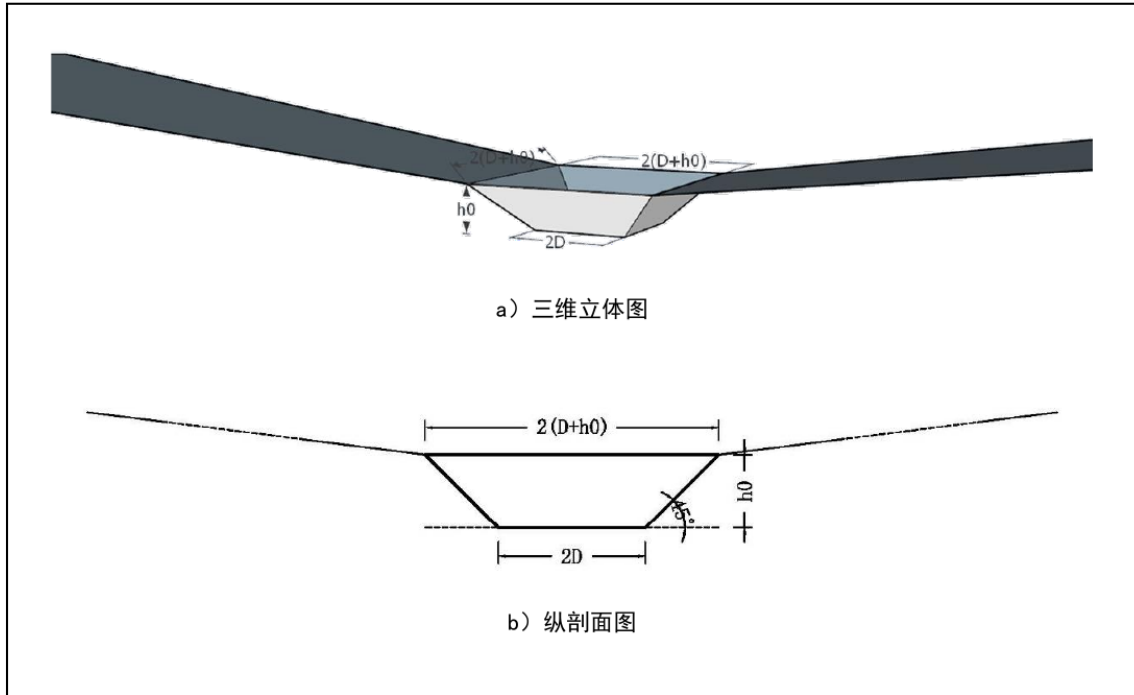

h_0 □ D □ □ □

OFV □ □ □ □

/ □ □ □ □ □ □ □ □ □ □

OFV

9.2 EASA PTS-VPT-DSN? Figure D-15 OFV

PTS VPT-DSN.D.455 Obstacle-free volume (OFV)

- (a) The obstacle-free volume, as depicted in Figure D-15, is created by extending vertically upward the outside edges of the SA up to height h_1 . The edges at height h_1 are then extended upwards linearly up to height h_2 to provide a funnel-shaped volume. At height h_2 , $0.5 D$ are added on each side of the VTOL procedure volume so that the dimensions of the obstacle-free volume at height h_2 are:
 - (1) the length ($TO_{back}+0.5 D$) behind the aircraft and the length ($TO_{front}+0.5 D$) in front of the VTOL-capable aircraft, referenced to the aircraft centre of the smallest enclosing circle when positioned on the FATO; and
 - (2) the width ($TO_{width}+1 D$).
- (b) The obstacle-free volume should not be penetrated by obstacles.

Note: A larger SA may be warranted for specific local conditions, e.g. severe aerology.

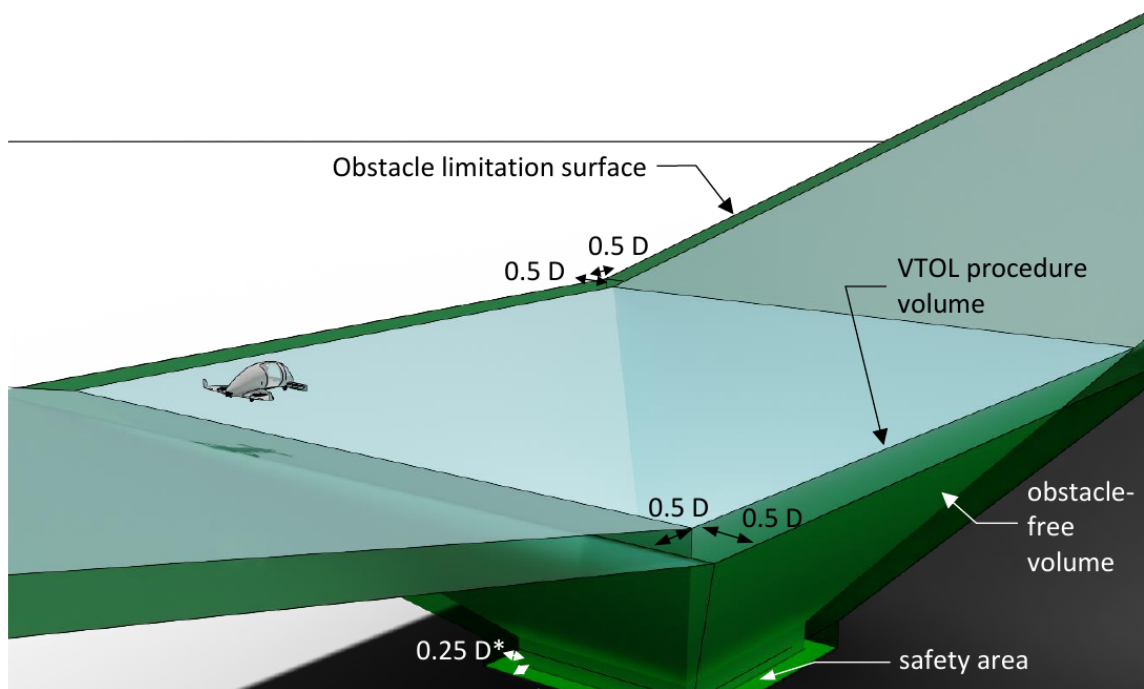

EASA □ OFV □ AFM □

OFV □

9.3 CASA AC139.V-01?FPA / VPS / OFV

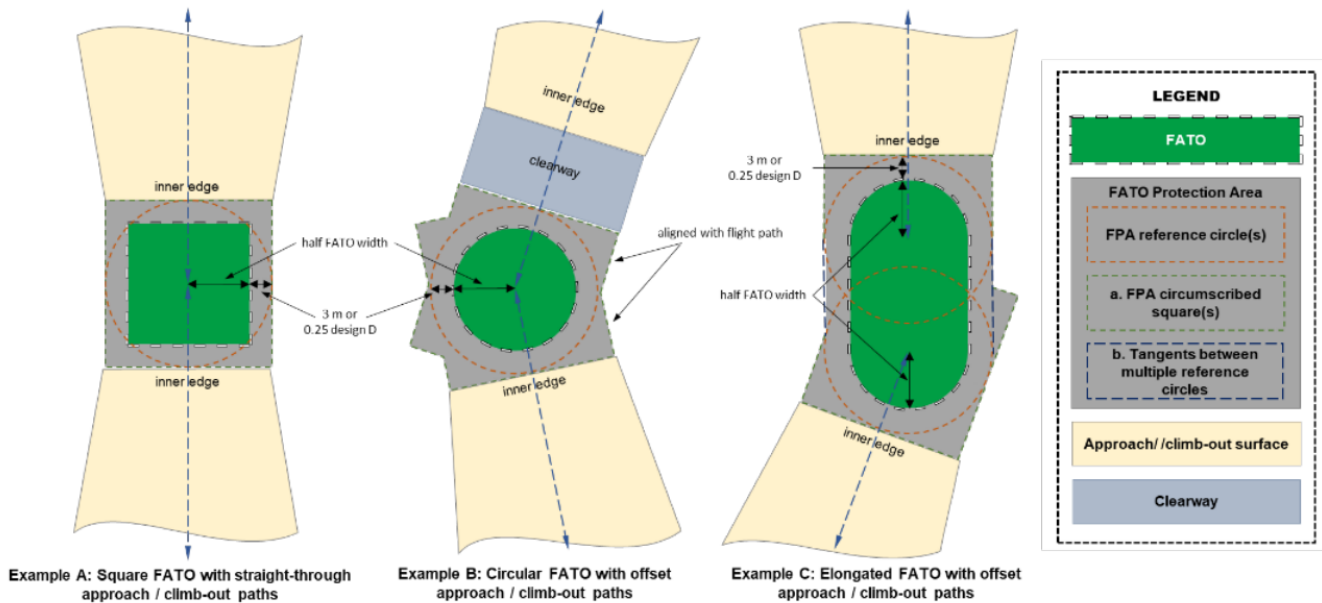

Figure 7 - Protection surfaces for vertiports without vertical procedures

4.2.3 Vertical Procedure Surface

- 4.2.3.1 A vertical procedure surface (VPS) should be established for where vertical procedures are used for landing or take-off from the vertiport.
- 4.2.3.2 The VPS is a surface that encompasses the area bordered by a circumscribed square(s) aligned with the intended aircraft flight path(s) centred on the VPS reference circle, as shown in Figures 8, 9 and 11.
- 4.2.3.3 A VPS should be free of obstacles.
- 4.2.3.4 A VPS reference circle should be established above and centred on the FATO.
- 4.2.3.5 The diameter of a VPS reference circle should be the diameter of the associated FPA reference circle, plus 1 Design D per 100 ft increase in height above the FATO.
- 4.2.3.6 The vertiport operator should determine the elevation of the VPS subject to the performance characteristics of the most demanding VCA intended to use the vertiport or the VCA operator's intended operational requirements.

4.2.4 Obstacle Free Volume (OFV)

- 4.2.4.1 An OFV should be established between a VPS and the associated FPA.
- 4.2.4.2 An OFV should be free of obstacles.
- 4.2.4.3 The OFV is a truncated cone extending between the edge of the FPA reference circle to the edge of the VPS reference circle, as shown in Figure 8, 9 and 11.

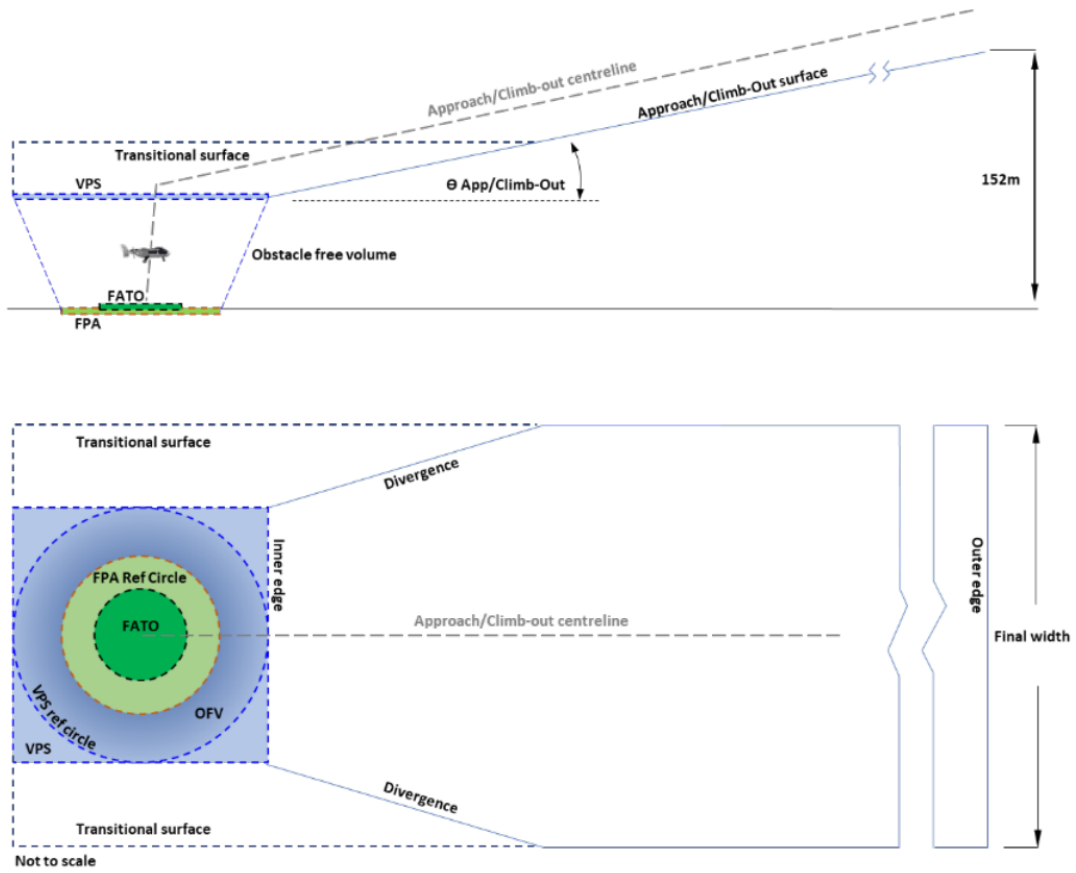
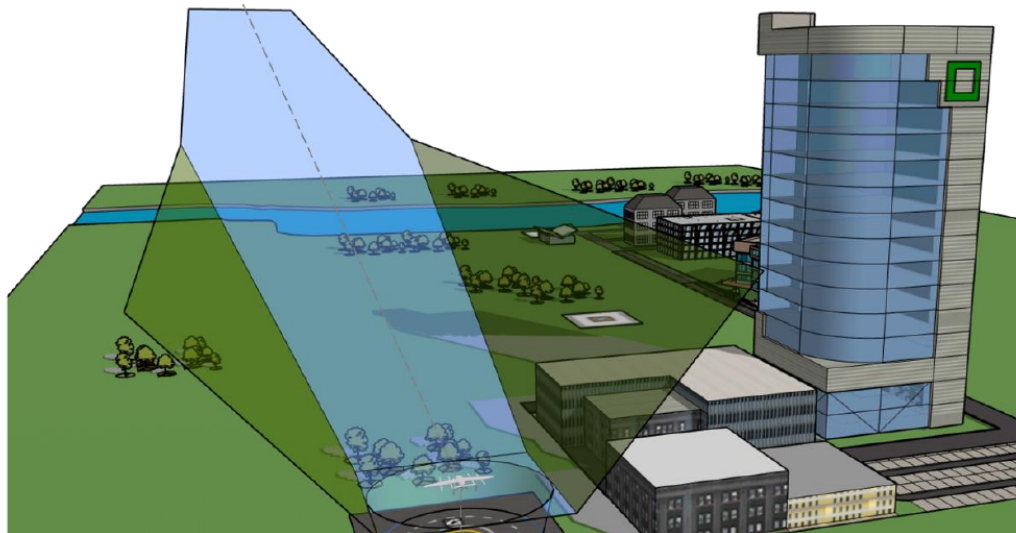

Figure 8 - An example OLS design for a vertiport accommodating vertical procedures



□□□□ CASA □ EASA □□□ OFV □□□ FPA □ VPS □ OFV □□□□□□

9.4 FAA EB105A? VFR Approach/Departure Surfaces

Figure 2-5: VFR Vertiport Approach/Departure Surfaces

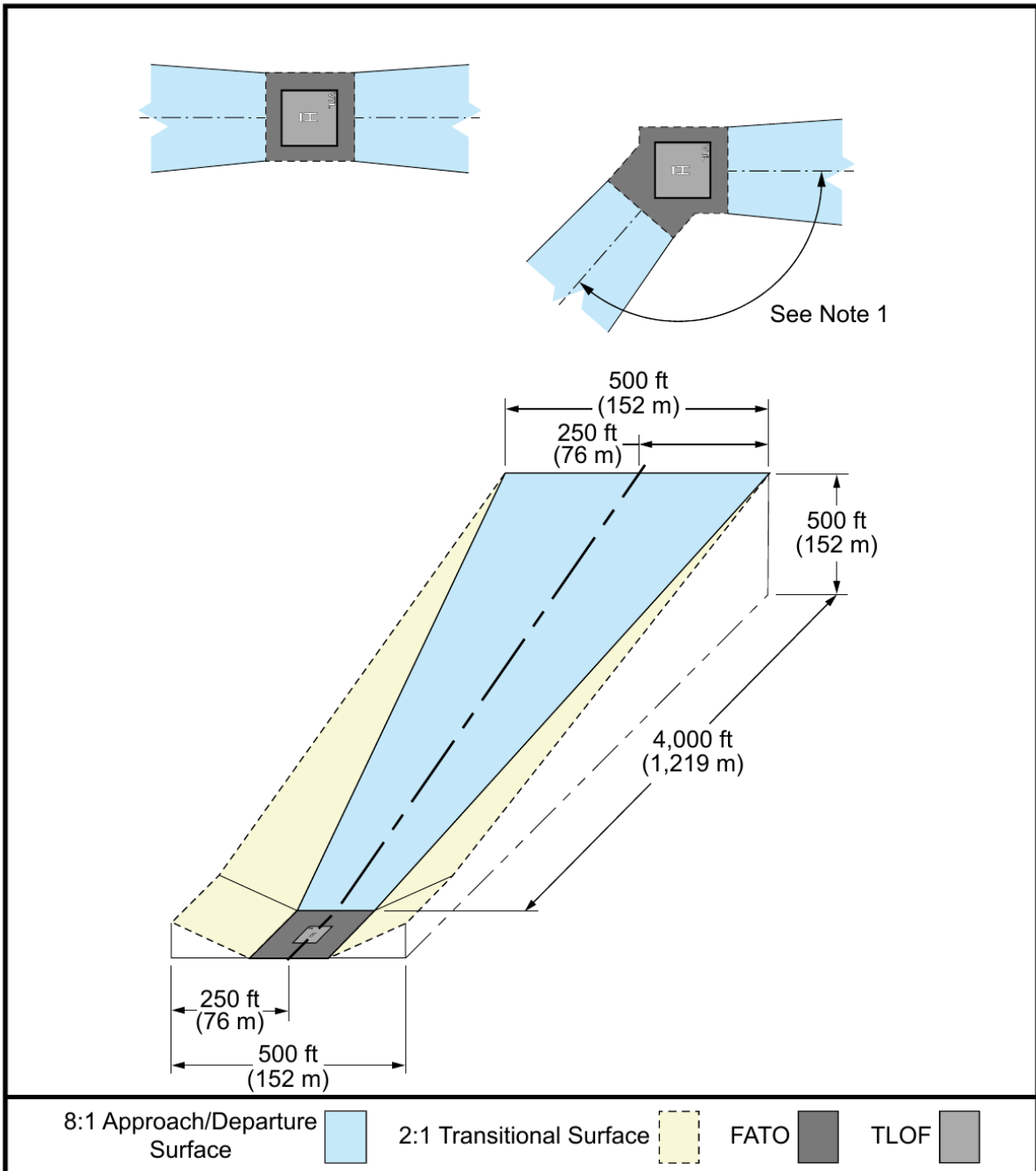

Note 1: The preferred approach/departure surface is based on the predominant wind direction. Where a reciprocal approach/departure surface is not possible in the opposite direction, use a minimum 135-degree angle between the two surfaces.

Figure 2-6: VFR Vertiport Curved Approach/Departure and Transitional Surfaces

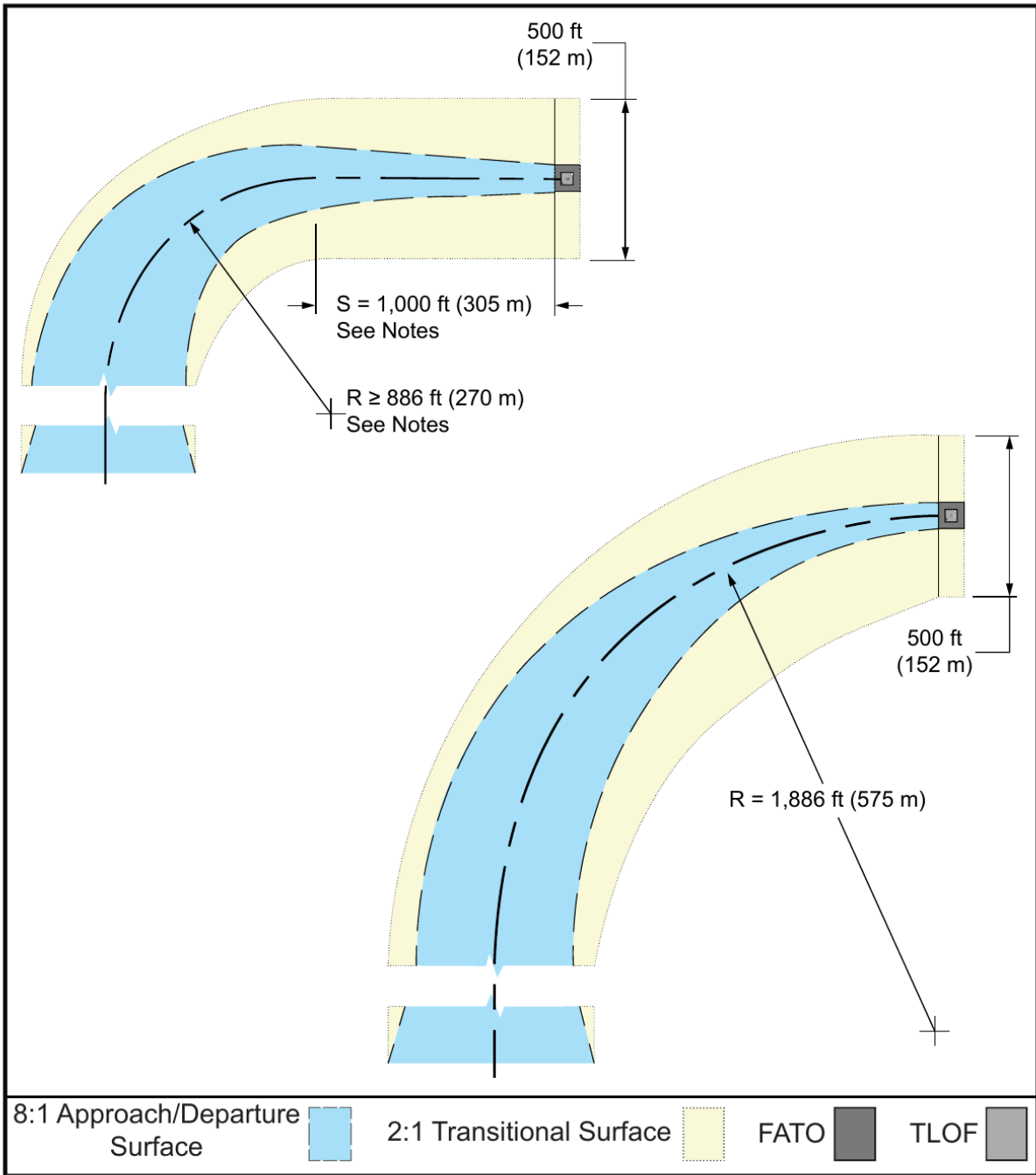

Note 1: Use any combination of straight portions of one curved portion using the following formula: $S + R \geq 1,886 \text{ ft (575 m)}$ and $R \geq 886 \text{ ft (270 m)}$, where S is the length of the straight portion(s) and R is the radius of the turn. Note that any combination $\geq 1,886 \text{ ft (575 m)}$ will work.

Note 2: The minimum total length of the centerline of the straight and curved portion is 4,000 ft (1,219 m).

Note 3: VTOL takeoff performance may be reduced in a curve. Consider a straight portion along the takeoff climb surface prior to the start of the curve to allow for acceleration.

FAA EB105A 14 CFR Part 77 imaginary surfaces 8:1 / 2:1
EASA OFV

9.5 MH5013-2023??? OLS ??

要求应同时考虑，具体见本标准第 8.6.2 条第 5 款。

【条文说明】本条第 4 款中，允许超出障碍物限制面的物体可能会限制直升机场的运行。



图 6.2.1-1 进近/起飞爬升面起始端形式



图 6.2.1-2 目视进近/起飞爬升面宽度

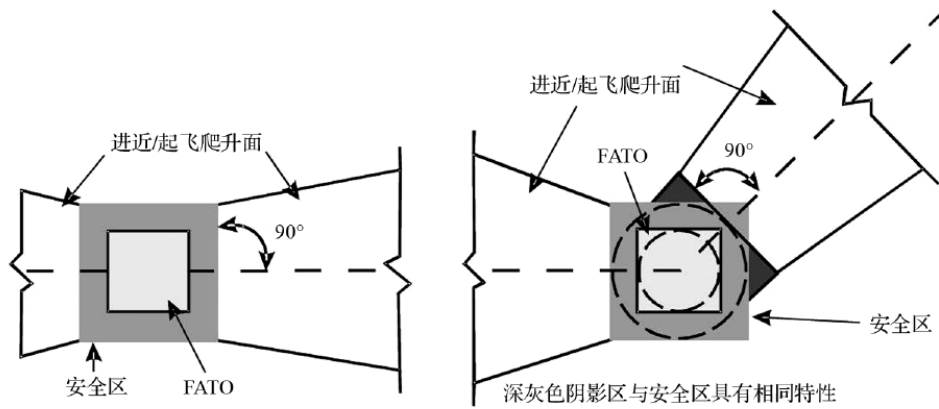

图例：

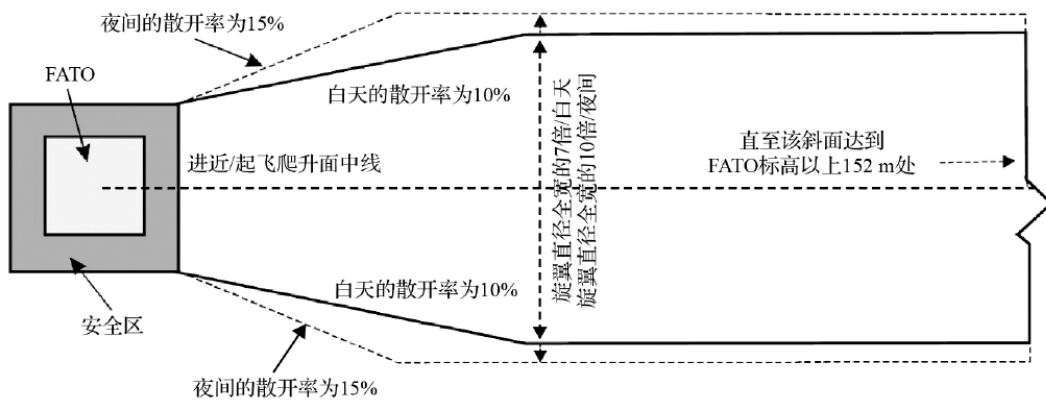
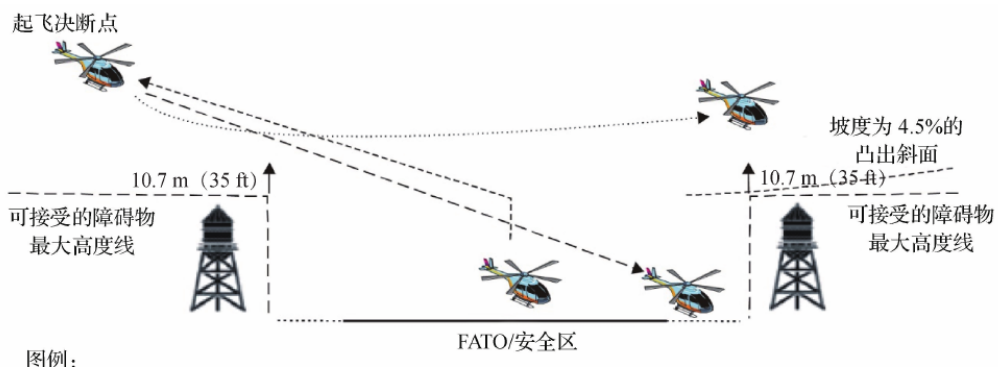
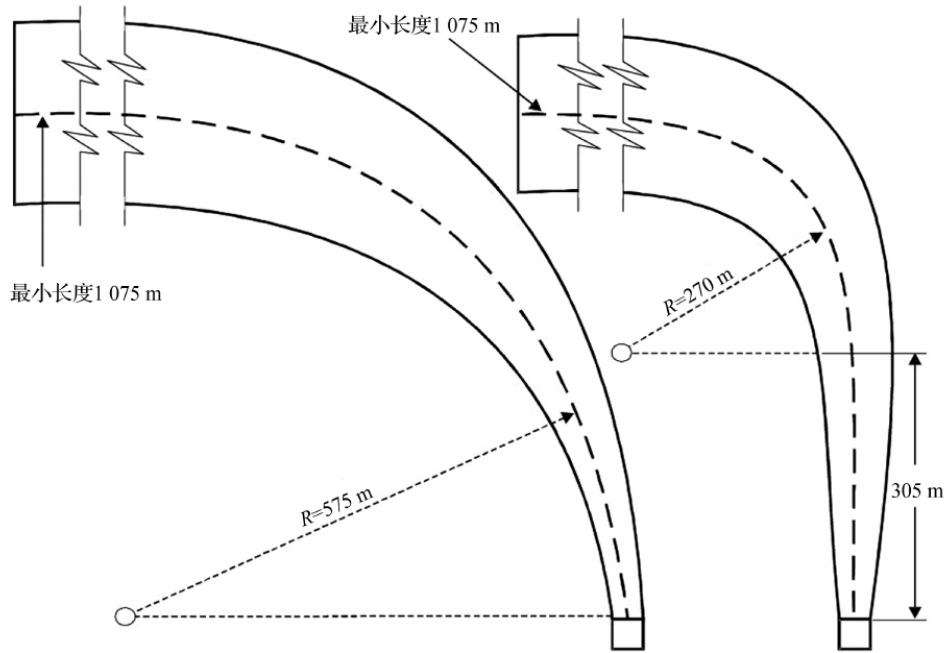

注：1 曲线和直线段的任何组合可以使用如下公式来确定： $S+R \geq 575\text{ m}$ 和 $S=305\text{ m}$ 时， $R \geq 270\text{ m}$ 。式中 S 为直线段的长度， R 为转弯半径。任何 $\geq 575\text{ m}$ 的组合均可行。

2 曲线和直线段中线的最小长度为 1075 m ，但是根据所用的坡度可以更长。更长的长度，见表 6.2.1-1。

3 直升机的起飞性能在曲线段会降低，因此应考虑曲线段开始之前沿起飞爬升面的直线段可允许加速。

图 6.2.1-4 目视曲线进近/起飞爬升面

平面图



纵剖面图



图1 Vertiport标准源流：同源不同支

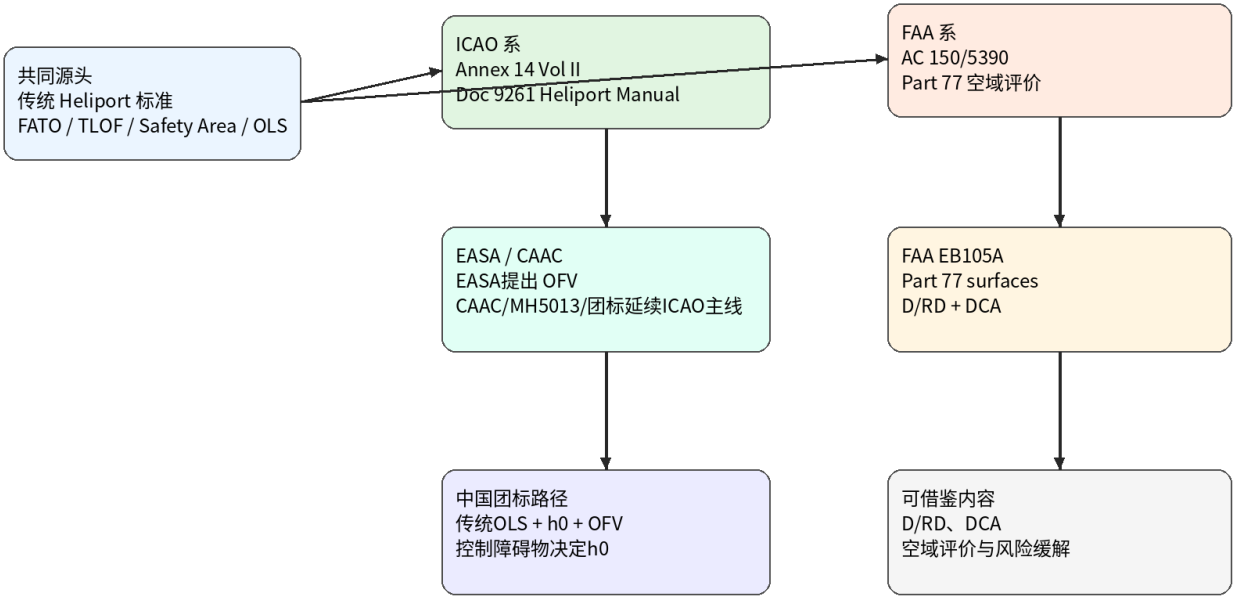

注：ICAO/EASA/CAAC与FAA均源自heliport；我国净空主线宜采用ICAO系，FAA作为参考和补强。

图2 ICAO/MH5013传统OLS：以安全区外边界为内边

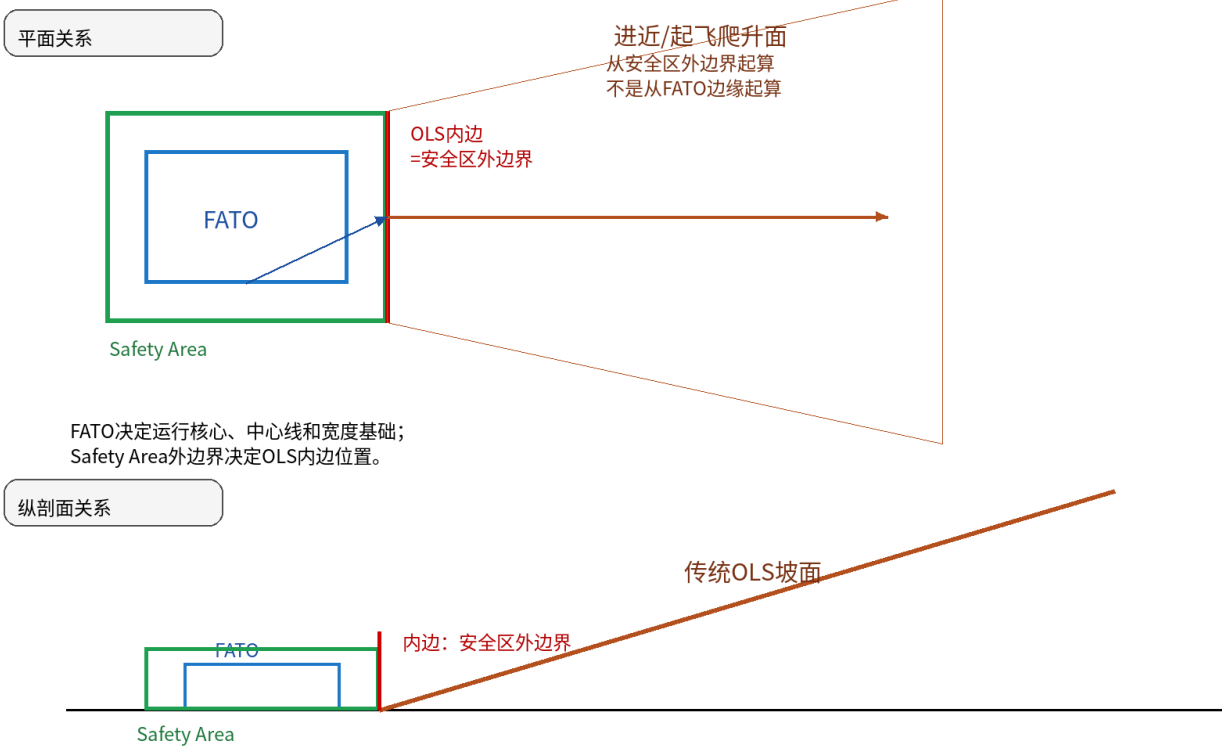

FATO决定运行核心、中心线和宽度基础；
Safety Area外边界决定OLS内边位置。

注：本图为ICAO/MH5013主线；FAA primary surface=FATO的表达不在本图适用。

图3 团标OFV: 抬高传统OLS起点, 保护垂直拉升过程

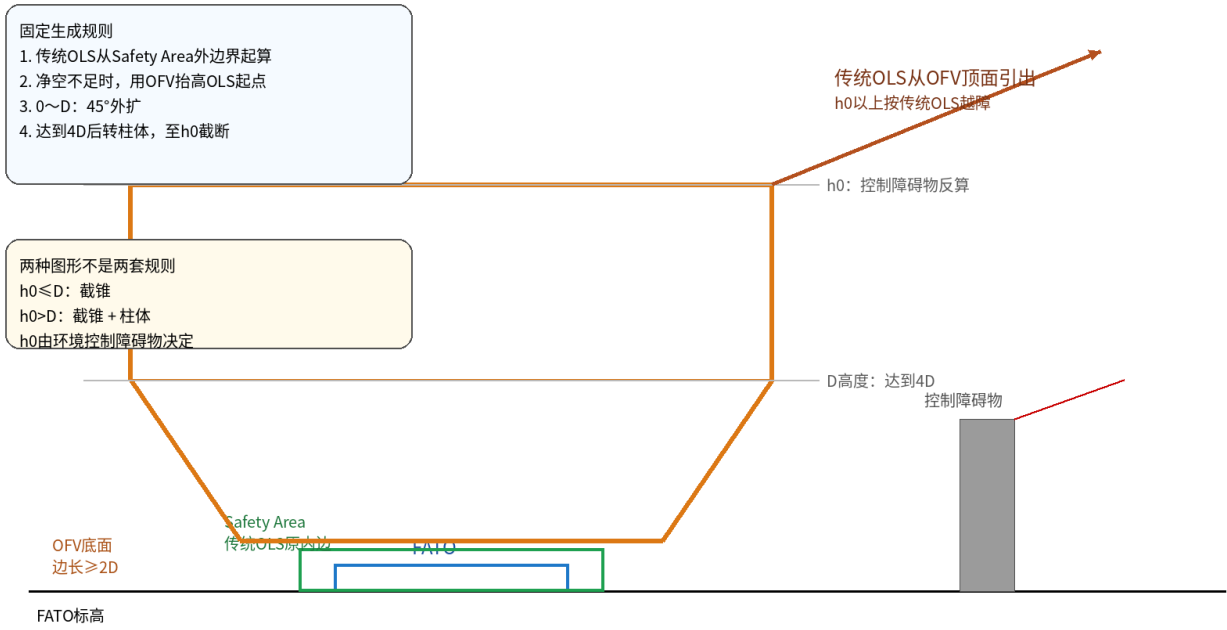

注: OFV底面用于保护垂直拉升过程; 传统OLS内边仍遵循ICAO/MH5013的安全区边界逻辑, 抬高后位于OFV顶面。

图4 ICAO/EASA/CAAC主线与FAA参考路径

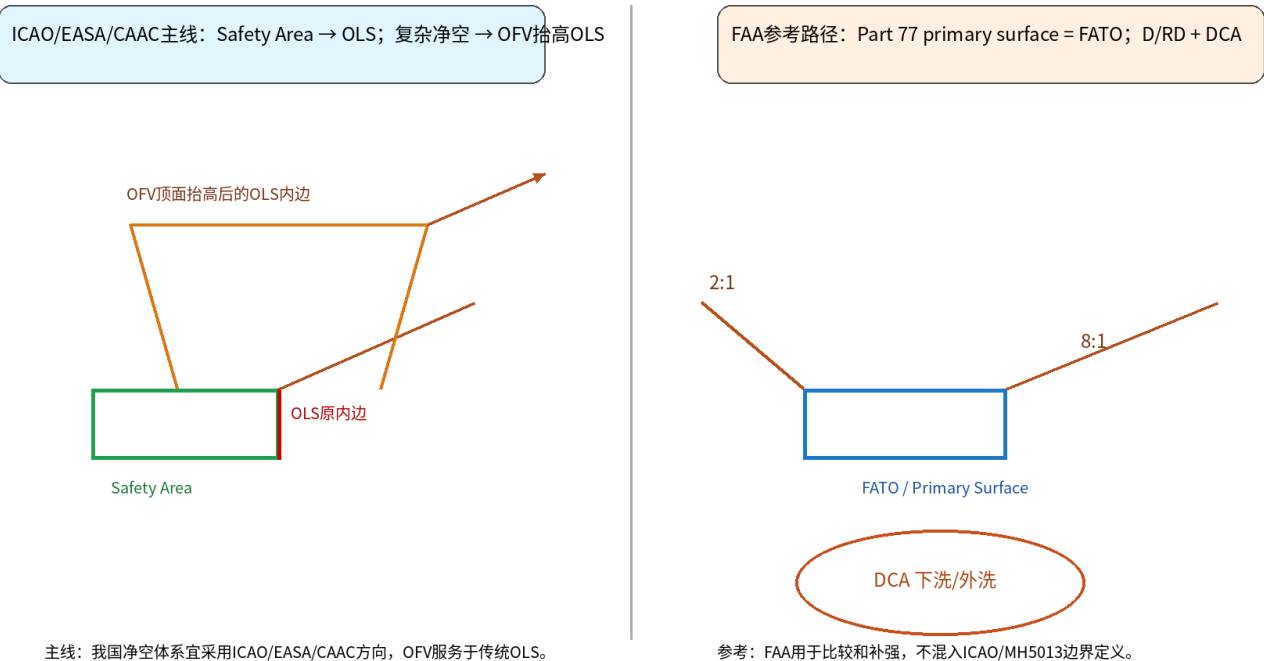

☐☐ #2

☐ Admin ☐☐ 2026-05-30 22:03:36 CST

☐ Admin ☐☐ 2026-05-30 22:28:22 CST